

Sliding Safety of Existing Gravity Dams - Final Report

Giovanni Ruggeri, *Chairman of the European Working Group*

SYNOPSIS. The European Working Group on “Sliding safety of existing gravity dams” started its activities in 2001 to examine the problem of the safety re-assessment against sliding for existing gravity dams. The attention of the Group was concentrated on conventional concrete gravity dams, in static loading conditions. This Final report illustrates the results of the activities carried out by the Group.

FOREWORD

The European Working Group on “Sliding safety of existing gravity dams” is composed by the following members, from 9 Countries:

- | | |
|-------------------------|------------------|
| - Giovanni Ruggeri | Italy (Chairman) |
| - Rita Pellegrini | Italy |
| - Moises Rubin de Celix | Spain |
| - Morten Berntsen | Norway |
| - Paul Royet | France |
| - Volker Bettzieche | Germany |
| - Walter Amberg | Switzerland |
| - Anders Gustaffsson | Sweden |
| - Tony Morison | United Kingdom |
| - Gerald Zenz | Austria |

This *Final Report* illustrates the results of the activities carried out by the Working Group. It is composed of the following sections:

- *Regulatory Rules and/or “Normal Practice”*

Information about Regulatory Rules, Guidelines or Normal Practice adopted in different Countries for the sliding safety assessment were collected and examined.

- *Safety assessment using site specific data*

Standard approaches may not fit well to existing dams, and safety re-assessments taking into account the peculiar characteristic of the dam under examination are called for.

2 SLIDING SAFETY OF EXISTING GRAVITY DAMS

- *Significant experimental experiences*

The Group decided to review significant studies relevant to experimental evidences, highlighting the findings judged of main interest.

- *Techniques for the safety assessment*

A summary of available numerical methods for the sliding safety assessment was prepared, highlighting capabilities and limits of the different methods, referring to both well-consolidated traditional methods and more recent methods able to study the dam response from service conditions to limiting states.

- *Three-dimensional effects*

The conclusion given by a 2D analysis of a single monolith is subject to caution if 3D load sharing mechanisms can be mobilised across adjacent monoliths.

TABLE OF CONTENTS

This Final Report is composed of five chapters. The Table of Contents of is the following:

INTRODUCTION

1. REGULATORY RULES – GUIDELINES - COMMON PRACTICE

2. SAFETY ASSESSMENT USING SITE SPECIFIC DATA

2.1 Geometrical features

2.2 External loads

2.3 Uplift pressures

2.4 Strength parameters

2.5 Three-dimensional effects

2.6 Bibliographic References

3. SIGNIFICANT EXPERIMENTAL EXPERIENCES

3.1 Examined studies

3.2 Tensile strength

3.2.1 *Concrete lift joints*

3.2.2 *Concrete-to-rock contact surface*

3.3 Shear strength

3.3.1 *Concrete lift joints*

3.3.2 *Concrete-to-rock contact surface*

3.4 Remarks / Comments

3.4.1 *Concrete lift joints*

3.4.2 *Concrete-to-rock contact surface*

3.5 Bibliographic References

4. TECHNIQUES FOR THE SAFETY ASSESSMENT

4.1 Limit equilibrium approach

4.1.1 *Hoek -Brown's strength criterion*

4.1.2 *Burton's strength criterion*

- 4.2 Deformable body approach
 - 4.3 Constitutive behaviour and models
 - 4.3.1 *Elasto-plastic approach*
 - 4.3.2 *Fracture mechanics applied to joints*
 - 4.4 Numerical models
 - 4.5 Coupled response
 - 4.6 Size effects on material parameters
 - 4.7 Modelling experiences
 - 4.7.1 *Elastic-plastic solution*
 - 4.7.2 *Non Linear Fracture Mechanics solutions*
 - 4.7.3 *LEFM solutions*
 - 4.7.4 *Coupled solutions*
 - 4.7.5 *The 5th International Benchmark Workshop*
 - 4.7.6 *Network IALAD*
 - 4.8 Conclusive remarks
 - 4.9 Bibliographic References
 - 5. THREE-DIMENSIONAL EFFECTS
 - 5.1 General remarks
 - 5.2 Information from the actual dam behaviour
 - 5.3 Structural analyses -Gravity dams with curved axis
 - 5.3.1 *Limit equilibrium approach*
 - 5.3.2 *The 7th International Benchmark Workshop*
 - 5.4 Structural analyses - Straight axis gravity dams
 - 5.5 Bibliographic References
- APPENDIX 1: REGULATORY RULES, GUIDELINES, NORMAL PRACTICE

INTRODUCTION

Examining the different aspects of potential interest, the Group decided to concentrate its work on the following main subjects:

- Regulatory Rules, Guidelines or Normal Practice adopted in different Countries for the sliding safety assessment, with specific attention to the safety reassessment of existing dams. An exhaustive inventory was beyond the scope of work of the Group. The aim was to gather sufficient information to enable useful comparisons and to evaluate the compatibility of the different approaches.
- Use of site specific data for the sliding safety assessment. Standard conventional approaches may be not suited to the safety re-assessment of existing dams, each existing dam being is a peculiar case, a unique prototype, particularly when in operation since long time. Therefore, the

4 SLIDING SAFETY OF EXISTING GRAVITY DAMS

Group discussed about the data and information that can be obtained about the actual dam behaviour and condition, by means of instrumental monitoring, surveys, inspections, in situ and lab tests.

- Significant experimental studies relevant to the response of concrete lift joints and concrete-to-rock contact surface. The review was limited to these discontinuities because, while the rock mechanics literature provides many evidences on the parameters ruling the shear response of joints in rock, comparatively less data are available about the actual properties of the dam base and lift joints.

- Numerical modelling. Well-consolidated traditional approaches establish appropriate safety margins to incorporate the uncertainties embedded in the methods. More recently methods to study the structural response from operational conditions to limiting states became available, mostly operational in finite element codes. Depending on the reliability of the available input information, these approaches can allow to release some conservatism embedded in the conventional approaches.

The attention of the Group was concentrated on conventional concrete gravity dams, in static loading conditions.

It must be pointed out that uplift pressures, probably the factor most influencing the sliding safety assessment, have been treated by a previous ICOLD European Working Group. Therefore, in this Final Report uplift pressures are not treated in detail, and reference is made to the “*Uplift Pressures Under Concrete Dams - Final Report*”, published in the Proceedings of the ICOLD European Symposium held in Geiranger (Norway) in June 2001.

1. REGULATORY RULES – GUIDELINES - COMMON PRACTICE

Through the co-operation of experts from different Countries, information about regulatory rules adopted in different Countries was collected and reviewed.

Some Countries have no regulatory rules specifically addressed to the assessment of the safety against sliding. In these cases, information was sought about Guidelines or techniques commonly applied in “normal practice”.

An exhaustive inventory of available regulatory requirements or applied practices was beyond the scope of work of the Group; instead it was aimed to gather sufficient information to enable useful comparisons to be made and to evaluate the compatibility of the different approaches.

In the review the main attention was paid to the European Countries. However, some non-European Countries were also included, as shown in the following table:

	Regulatory Rules	Guidelines, “Normal Practice”
Italy	•	
Spain	•	
Portugal	•	
Germany	•	
Norway	•	
United Kingdom		•
France		•
Switzerland		•
Sweden		•
Austria		•
Canada		•
USA		•
China	•	
India	•	

The information gathered for each Country is given in Appendix 1. Some synthetic comments and comparisons are given hereinafter.

Most comments are relevant to the basic criteria for the safety assessment against sliding and related main factors and parameters. It must be reminded that ancillary conditions or criteria are often given in Regulatory Rules or Guidelines (such as: limitation of the tensile stresses, joint opening, compressive stresses), which are not examined hereinafter.

It must also be reminded that the comparison between different Rules/Practices referring to single criteria/parameters is not easy, and could be misleading if all the possible differences between different assessment rules are not duly taken into account. As an example, different factors of safety may be related to different criteria adopted to define the exceptional or extreme loads, or to define the strength parameters.

Consequently, care has been taken in the selection of the comparisons. Even so, the comparisons reported hereinafter are given to stimulate the examination of the Reg. Rules and Guidelines synthesised in Appendix 1, not to avoid it.

6 SLIDING SAFETY OF EXISTING GRAVITY DAMS

▪ *Level of detail*

In all the examined Regulatory Rules or Guidelines the basic elements of the sliding safety assessment are defined: loading combinations, criteria for the assessment, required safety factors. Of course, the Regulatory Rules are usually more concise, while more technical details are found in non-regulatory Guidelines. The Guidelines of the Canadian Dam Safety Association are particularly rich of helpful technical details.

▪ *Loading combinations*

In most of the examined Countries reference is made to three levels of Loading Combinations: Usual – Unusual – Extreme, or equivalent terms.

In few countries (Spain, Portugal) reference is made to two levels of Loading Combinations: Usual – Exceptional.

However it must be noted that the loads - mainly the exceptional ones - may be not always defined with identical criteria. This must be clearly reminded when comparing the different Reg. Rules or Guidelines in terms of assessment criteria and related safety factors.

▪ *Criteria for the sliding safety assessment*

The basic criterion for the safety assessment against sliding is the ratio between the driving forces and the resisting forces (available shear strength) along the considered sliding surface. This criteria is used in almost all the examined Reg. Rules/Guidelines.

Only in Italy (Reg. Rules) and Sweden (Svensk Energi Guidelines) a simpler criteria is applied: the safety assessment is based on the simple ratio T/N between the resultant of the forces parallel (T) and perpendicular (N) to the sliding surface. In Swedish Guidelines the maximum allowed T/N value depends on the loading combination (0.75: normal loads, 0.90: exceptional, 0.95: accidental). In Italian Reg. Rules the maximum allowed T/N value does not depend, in practice, on the loading combination.

Some additional assessment criteria are sometimes expressed. For instance, in the Canadian Guidelines it is stated that, in addition to the basic sliding criterion, the shear stresses over the zone of calculated compression should be compatible with the available shear strengths, to guard against diagonal tension cracks in areas of much higher stresses than the average shear stress.

▪ *Sliding surfaces*

All the examined Reg. Rules/Guidelines explicitly state that the assessment against sliding has to be carried out considering the potential sliding surfaces in the dam body, at the dam-foundation interface and in the foundation.

The only exception is the Italian Reg. Rules, where the consideration of potential sliding surfaces in the foundation mass is not explicitly stated.

▪ *Shear strength*

In general the available shear strength is expressed by a Mohr-Coulomb criterion and consists of the frictional and the cohesion component.

Many Reg. Rules/Standards do not explicitly state if peak or residual values have to be used for the strength parameters (friction angle and cohesion).

This is clearly expressed only in Portuguese Reg. Rules (peak values for the Usual Loading Combinations, residual values for the Extreme Loading Combinations) and in Canadian Guidelines (peak or residual values may be used, and they are related to different factors of safety).

The BuRec Guideline (USA) points out that the adopted shear strength parameters must be compatible with the maximum displacement that can be allowed on the sliding plane without causing unacceptable stress concentrations.

Only the Canadian and BuRec Guidelines explicitly state that the scale effects must be carefully considered in determining, from test results, the shear strength parameters to be used in the safety assessment.

In the Canadian Guidelines, in addition to the Mohr-Coulomb criterion, other approaches are also considered (complete curve of shear resistance versus normal load, joint roughness and alteration parameters). The use of a complete curve of shear strength versus normal load for materials other than intact rock is required also in the BuRec Guidelines

The Canadian Guidelines underline that caution must be used for the shear strength of lift joint or concrete/rock interface which may have been treated with cement-water slurry "bonding coat", and for joints heavily degraded by seepage.

▪ *Shear strength – Reference values*

Some Reg. Rules/Guidelines (China, Canada, BuRec, Norway) define also reference values for the shear strength parameters, that - in absence of specific test data - can be used:

- ✓ in preliminary evaluation phases (BuRec, China);
- ✓ in association with larger factors of safety (Canada)

Reference maximum values for shear strength parameters for rock foundation and lift joints, to be used if tests are not available, are given also in the Norwegian rules.

About suggested reference parameters for concrete, a comparison is given – as an example – in Table 1.1 (the large difference between the cohesion given by the “0.1 Rc” expression and the others must be underlined).

8 SLIDING SAFETY OF EXISTING GRAVITY DAMS

Table 1.1: Reference parameters for concrete. (R_c : compressive strength)

USA (BuRec)	Canada (CDSA)	Norway	China
Concrete friction (tg. Φ)			
1.0	peak : 1,43 residual : 1.0	1.0	1.08 - 1.25
Concrete cohesion			
0.1 R_c	mass : $0,17 R_c^{1/2}$ * lift joint: $0,085 R_c^{1/2}$ *	- $0,085 (R_c)^{1/2}$ *	- 1.16 - 1.45 *

* : (MPa)

▪ *Factors of Safety*

– All the Reg. Rules/Standards define different factors of safety for the different loading combinations. The only exception is the Italian Regulation.

– Some Reg. Rules/Guidelines (Spain, Portugal, China, India, France, and Switzerland) refer to different reduction factors (safety factors) that are applied separately to the cohesion and friction parameters.

In these cases, the safety factors applied to cohesion are much larger than those applied to the friction coefficient, as shown in Table 1.2 (where only Usual Loads condition is reported, for a homogeneous comparison).

This is clearly due to the larger uncertainties in the evaluation of the cohesion.

– In all the other Reg. Rules/Guidelines (Canada, BuRec, Germany, United Kingdom, Norway, France) reference is made to a single global safety factor (ratio between sliding forces and total shear strength).

In these cases, two "typical sequences" can be noted in the values of the safety factors required for Usual → Unusual → Extreme loading combinations:

- ✓ a "steeper" one, with safety factors in the order of $3 \rightarrow 2 \rightarrow 1$;
- ✓ a "smoother" one, with safety factors in the order of $1.5 \rightarrow 1.3 \rightarrow 1$;

See Table 1.3 in which, for comparison purpose, the safety factors required at the dam-foundation interface are reported.

The two "sequences" are most probably related to different criteria in the selection of the shear strength parameters.

Table 1.2 - Safety factors for cohesion and friction (for “Usual Loads”)

	Strength Reduction Factors					
	Spain	France (1)	Portugal	Switzerland	China	India
Friction Φ	1.5	1.5	1.5 ÷ 1.2	1.5	1.3	1.5
Cohesion C	5.	3.	3 ÷ 5	5.	3.	3.6 ÷ 4.5 (2)

(1) - *Coyne & Bellier practice*

(2) - *Min value: dam body, dam-foundation surface. Max value: not thoroughly investigated foundation*

Table 1.3 - Safety Factors (at the dam-foundation interface)

	Safety Factors						
	France			Germany	Austria	Switz..	Norway
	(1)	(2)	(3)			(4)	(4)
Usual loads	4.	1.33	1.5	1.2÷1.5	1.5	1.5	1.5
Unusual loads	2.7	1.1	1.2	1.2÷1.3	1.2÷1.35	1.3	1.1
Extreme loads	-	1.05	1.0	1.2	1.1	1.1	1.1

(1); (2); (3): *Barrages en aménagement rural ; EDF ; Coyne & Bellier*

(4): *When cohesion is assumed = 0*

	Safety Factor			
	Canada-CDSA		United Kingdom	USA- BuRec.
	(5)	(6)		
Usual loads	1.5	3.0	3.0	3.0
Unusual loads	1.3	2.0	2.0	2.0
Extreme loads	1.0	1.3	1.0	1.0

(5); (6): *Residual strength; Peak strength (no tests)*

10 SLIDING SAFETY OF EXISTING GRAVITY DAMS

As a confirmation of that, in the Canadian Guidelines both the sequences are used, related to the use of peak strength (steeper sequence: $\sim 3 \rightarrow \sim 2 \rightarrow \sim 1$) or residual strength (smoother sequence: $\sim 1.5 \rightarrow \sim 1.3 \rightarrow \sim 1$).

– In some Reg. Rules/Standards (Germany, China, United Kingdom, BuRec, India) different factors of safety are required for sliding surfaces in the dam body, at the dam-foundation contact, in the foundation.

In these cases the same safety factors are required for concrete-concrete and concrete-rock surfaces, and larger safety factors (from + 10% to + 30%) are required for the sliding surfaces within the foundation.

– Very interesting for the safety assessment of existing dams is the definition of different safety factors depending on the modalities used to evaluate the shear strength parameters.

In German Regulation different safety factors are related to the use of best estimate or lower bound values.

In the Canadian Guidelines and Norwegian Regulation, reduced safety factors are used if the strength parameters are determined by tests, and larger safety factors have to be used if the strength parameters are derived from technical literature, without tests.

In the Guidelines of the Canadian Dam Safety Association the reduction of the safety factors (no tests \rightarrow with tests) is the following:

- ✓ 3 \rightarrow 2 (Usual Loads)
- ✓ 2 \rightarrow 1.5 (Unusual Loads)
- ✓ 1.3 \rightarrow 1.1 (Extreme Loads).

In the Norwegian Regulation it is the following:

- ✓ 3 \rightarrow 2 (Usual Loads)
- ✓ 2 \rightarrow 1.5 (Unusual and Extreme Loads).

In the Canadian Guidelines it is also stated that if the safety factors computed using peak strength do not comply with the required minima values, the dam stability may still be considered acceptable, provided the safety factors computed using residual values exceed the required minima values.

– Only Chinese Standards apply a semi-probabilistic approach, distributing the uncertainties among various partial safety factors applied to the loads, material properties, etc. The French Working Group on gravity dams is currently preparing new guidelines using concepts issued from the semi-probabilistic approach.

2. SAFETY ASSESSMENT USING SITE SPECIFIC DATA

Regulations specifically addressed to the safety re-assessment of the existing dams are not available in any of the examined Countries (see Chapter 1).

The technical Regulations/Guidelines applied in the European Countries reflect the current state of the art for dam design and construction.

But, when an existing dam does not comply with such current safety criteria and standards, it is a very controversial and debated matter if this requires actions to increase the safety of the dam.

The evident heavy economical impact of this problem makes the relevant technical debate important and delicate.

On one hand there is a tendency to give credit to a dam for a long service life without significant problems. But “how much credit”, how to evaluate it, is still an open question.

On the other hand the design and construction of older dams often come short of the quality that can presently be reached, and any identified or suspected ageing symptom induces to more cautious and conservative approach.

The difficulties in defining a common standard for the safety re-assessment of the existing dam is emphasised by the fact that every existing dam is a peculiar case, a unique prototype. When in operation since long time, dams tend to increase their unique characteristics, being so peculiar the conditions/behaviours/events/etc. they experienced during their life.

Consequently, standard approaches do not fit them well, and safety re-assessments taking into account the peculiar characteristic of the dam under examination are called for.

The use of site/dam specific data is highly recommendable, to avoid both compounding of conservatism in generic or standard assumptions, and overlooking of geological or structural defects/deterioration/ageing.

It is then important to derive from the dam in its actual condition, and from its documented history, as much information as possible.

The main information sources are the following:

- Design and construction documentation. Construction documentation can provide information not documented elsewhere (geological details, foundation treatment, excavation/construction methods/equipment, construction problems, “as-built” conditions). Unfortunately, it is seldom available for oldest dams.
- Periodic inspection and maintenance records. They may provide indication of foundation or dam problems requiring specific deepening.

12 SLIDING SAFETY OF EXISTING GRAVITY DAMS

- Monitoring data, illustrating the actual behaviour over a long time. For the sliding safety assessment some measured data are of primary interest (measured uplift pressures, information about localised strain concentration and differential movements, etc.).
- In situ and laboratory investigations and tests.

When looking for useful data the resources must be concentrated on those factors and parameters most heavily influencing the assessment. Preliminary analyses (“sensitivity analyses”) may be used to examine the influence of the various factors and to identify the most important ones.

A staged approach is then usually applied:

- Review of existing data: site geological records; construction documentation; operation, maintenance and periodic inspection records; monitoring data; experience at other dams on similar foundation; literature data; etc.. One basic point is the identification of the potential sliding bodies, according to suspected or recognised planes of weakness, in the foundation and in the dam body. The recognition of unfavourably oriented main discontinuities is crucial. The inclination, persistence and possible combinations of geological discontinuities in the foundation should be evaluated, as well as the possible presence of weak or deteriorated lift joints.
- Preliminary or “first-level” analyses. Simple computational methods are usually used in this phase. Specific care should be given to the foundation parameters, shear strength and uplift. If adequate safety factors are evaluated in the “first level” analyses, no additional work or limited field investigation may be required, depending on the level of conservatism in the assumed parameters. These analyses are therefore useful to identify those cases requiring specific deepening.
- Additional site data. The level of efforts required for additional site data depends on many factors: quantity and quality of the already available knowledge, uniformity of the foundation, identified problems, proximity of the calculated safety factors to the acceptance criteria, etc. A complete investigation may include geological deepening, inspections, boring and coring, in situ and laboratory tests, installation of additional monitoring devices.
- Final stability assessment.

Several examples of sliding safety assessment using site specific data, in particular for uplift pressures and strength, are given in a comprehensive research study described in Ref. 2.1 (EPRI,1992).

The conclusions of the study underline that the use of measured data, tempered with a thorough knowledge of site geology, reduces the uncertainties in stability evaluations and may consequently justify the use of lower factors of safety. Minimum acceptable factors of safety should be consistent with the reduced uncertainty in the analysis.

The same concept is expressed also in Ref. 2.2 (Soriano et al, 1998), in which the use of differentiated safety factors, depending on how the strength data are evaluated, is proposed.

Reduced safety factors related to the reduction of uncertainties in the definition of strength parameters are also expressed in some Reg. Rules/Guidelines (Canada, Norway, Germany, see Chapter 1).

In the Canadian Guidelines and in Norwegian Regulation, if the strength is determined by tests the corresponding safety factors are lower than those to be used if the strength parameters are derived from technical literature. In German Regulation different safety factors are related to the use of best estimate or lower bound strength values.

A semi-probabilistic approach, in which the various uncertainties are separately faced by means of corresponding partial safety factors, could be an interesting tool to take into account the available knowledge for an existing dam. But this approach is currently not used in any European Country (see Chapter 1).

Hereinafter some comments are given about different aspects involved in the sliding safety re-assessment.

2.1 Geometrical features

For old dams it may happens that “as built” documentation is not available, or not updated to the current situation. If so, or in case of doubts, the actual geometries must be checked.

Some geometrical details may be rather important in the sliding safety reassessment. Among them, the dam-foundation contact surface and the lift joints deserve careful consideration.

Dam-foundation contact surface

In absence of reliable as-built documentation, corings are used to identify the dam-foundation contact surface. A detailed description of the contact surface may be expensive, considering that each coring gives information in one point only.

14 SLIDING SAFETY OF EXISTING GRAVITY DAMS

This aspect could also be investigated by sonic tomography; effective results may be obtained when the sonic properties of the concrete are remarkably different from those of the foundation.

Sloping lift joints

Lift joint sloping in the direction of the reservoir is desirable (credit for sloping lift joint is given in many modern design rules).

Construction documentation is the basic source of information about the “as built” lift joints condition. If not available, the lift joints can be checked by coring and sampling. However, it may be difficult to identify clearly the lift joints in core samples. They are usually readily discernable only if mortar or laitance layers were used during the construction, or in case of very deteriorated joints. When reliable identification is derived from documentation or cores, the actual sloping of the lift joints should be used in the safety assessment.

2.2 External loads

Hydrostatic load

Longer the operation of the dam, larger (usually) the set of site specific data (reservoir water level, rainfall, discharged flow, etc.) available for the re-evaluation of the maximum flood and corresponding reservoir level. The evaluation is therefore more reliable, compared to the design phase.

For old dams the design maximum flood was defined using methods much simpler than those currently applied. Consequently, more severe maximum flood may easily result from the hydrological re-evaluation.

Dead load

The actual unit weight of the dam body can be evaluated by lab tests on cored samples. The actual moisture of the cored samples shouldn't be modified.

In case of very large aggregates (“cyclopean concrete”) cored samples may be not representative, and specific test on the complete core may be required. As an alternative, the core stratigraphy should be examined and the presence of very large rock blocks in the concrete mass taken into account through a weighted average of the concrete and rock blocks weight.

Sediment load

The elevation of the sediment at the dam upstream face can be measured and the geo-technical properties of the sediments should be tested.

2.3 Uplift pressures

Uplift pressures are one of the factors most heavily influencing the sliding safety assessment.

It is consequently important that they are monitored.

The importance of measured uplift pressures is evident, considering that:

- A change in the external forces acting in a sliding assessment may only be brought by a variation of the piezometric head along the major discontinuities.
- The actual uplift pressures can vary substantially from common assumptions used in the design phase and from standard uplift pressures distributions.
- Standard uplift pressures distributions may be severely conservative, and if used in sliding safety re-assessment many dams would require modification to meet safety standards. A better knowledge of the actual uplift pressures distribution can contribute to avoid unnecessary modifications.

The uplift pressures have been treated by the previous European Working Group “*Uplift pressures Under Concrete dams*”, which examined in detail the following topics:

- Regulatory rules / “Normal practice”
- Measured uplift pressures; influence of various factors.
- Numerical modelling.
- Techniques for clearing drainage systems.

So, reference is made to the “Final Report” of this Working Group (Ref. 2.3), for detailed information on the subject.

The evaluation of uplift pressures distribution to be used in a safety re-assessment must be based on a good knowledge of the site geological conditions. Such knowledge is necessary, but it may be not sufficient because, as discussed by Terzaghi as early as 1925, “*minor geological details*” (defined as “*features that can be predicted neither from the results of careful investigations of a dam site nor by means of a reasonable amount of test boring*”) can have a critical impact on uplift pressures.

Specific relationships between geological features and measured uplift pressures could not be established in any of the recent studies reviewed in Ref. 2.3.

Furthermore, the evaluation of the uplift pressures by means of numerical analyses is unavoidably affected by several uncertainties. The numerical modelling of the flow of water through low permeability media (rock, concrete) with discontinuity surfaces (rock joints, cracks, rock-concrete interface, lift joints, etc.) is not an easy task. It is generally difficult, or impossible, to have a complete knowledge of such discontinuities and of

their behaviour under different loading conditions, the water flow along each surface being affected by a combination of several factors (i.e. location, aperture, surfaces roughness, contact area, curvature, infilling materials, laminar or turbulent flow, steady or transient state, etc.).

In addition, the strong influence of the foundation treatments (grout curtains, cut-offs, drainage systems, etc.) cannot be neglected. From the numerical modelling point of view, they are further “artificially induced” difficulties.

Therefore, monitoring data are the most valuable information to take into account the uplift pressures in the safety re-assessment of an existing dam. To this aim, the measured uplift pressures must be carefully scrutinised to evaluate their reliability and adequacy (in terms of number and location of the measurement points, frequency of reading, type of instruments, etc.).

Attention must also be paid to several aspects, such as the following:

- Possible non-linear response of uplift pressures to headwater variations. The response may be characterised by increasing or decreasing gradients with reservoir level, depending on how the discontinuities are influenced by the stresses induced by the dam-reservoir system.
- Rate of uplift response. It may be an important aspect, because exceptional loading conditions may be of short duration. However, it is unlikely that significant time lag exists in rock foundations.
- Seasonal uplift variations, due to thermal variations. The seasonal thermal variations change the stress-strain distribution in the dam body and in the foundation, and they can consequently change the joint aperture and the uplift pressure distribution. The temperature variations can also influence the degree of non linearity in the response of the uplift pressures to headwater fluctuations.
- Possible high spatial variability of the measured data. Pressures measured at rather close points may be significantly different, and the extrapolation - or enveloping - of uplift pressures from a limited number of measurement points should be critically reviewed.
- Extrapolation of measured uplift to higher water levels (exceptional loading conditions). Reasonable and conservative extrapolation must be based on a thorough understanding of the behaviour in normal conditions. Possible slow drifts (slow variation in time), and possible sudden variations when reaching exceptional reservoir levels, must also be evaluated. The latter condition is not very probable for gravity dams transmitting low stress levels to the foundation.

2.4 Strength parameters

The evaluation of the strength parameters is required for any suspected or recognised plane/surface of weakness,

- in the foundation mass,
- at the concrete-to-rock contact surface,
- in the dam body (lift joints).

The quantities of interest depend on the computational method selected for the safety assessment. Tensile and shear strength are in any case the basic parameters.

The experimental evaluation of shear and tensile strength is based on coring, sampling, laboratory tests on samples, in situ strength tests.

Geophysical tests (such as sonic tomography) may be useful to investigate the homogeneity of the areas of interest, and to address the boring and testing activities.

A reasonable number of tests are usually necessary to define the strength parameters. This experimental evaluation may be expensive and unavoidably constrained by obvious limitations. As an example, a coring through the dam body is required to retrieve one single concrete-to rock contact sample.

It is therefore important to make full use of the data available in technical literature, to be used for:

- estimating strength data for preliminary or “first level” analyses,
- estimating the benefits of specific site investigations,
- improving confidence in limited site data.

The rock mechanics literature provides many evidences on the parameters ruling the shear response of joints in rock, as well as on applicable constitutive models. It represents a very rich and valuable information source.

Comparatively, less data are available about the strength along the dam-foundation contact surface and the lift joints. However, the literature review presented in Chapter 3 (“*Significant experimental experiences*”) points out that also for this subject a good number of significant experimental studies are available. Some studies are based on a large number of tests and have wide aims. Some others are more restricted and finalised. It is then important to identify, within the available literature, the data more closely corresponding to the actual situation under examination.

When reference is made to technical literature data, it is important to check their “validity conditions”. As an example, the results synthesised in

18 SLIDING SAFETY OF EXISTING GRAVITY DAMS

Chapter 3 apply to competent concrete. Some of them were mostly based on samples from dams in operation, therefore including possible natural ageing effects, but they do not include concrete affected by specific pathologies (such as, as an example, alkali-aggregate reaction)

2.5 Three-dimensional effects

As detailed in Chapter 5, possible 3D effects may have a significant influence on the sliding safety. Usually neglected in the design of new dams, they should not be neglected in the safety re-assessment of existing dams, in those cases where they play an effective role.

Information about 3D effects may be derived from the monitoring data, and specific investigations and tests can be carried out to derive useful information and to overcome uncertainties and difficulties to be faced in a 3D numerical analyses (see Chapter 5, “*Three-dimensional effects*”).

2.6 Bibliographic References

- [2.1] - Stone & Webster Engineering Corporation, “*Uplift Pressures, Shear strength and Tensile Strengths for Stability Analysis of Concrete Gravity Dams - Final Report*”, EPRI TR-100345, Project 2917-05, August 1992.
- [2.2] - Soriano A.; Sánchez F.I. “Evaluation of safety against foundation failure of concrete dams”, Proceedings of the International Symposium on New Trends and Guidelines on Dam Safety, Barcelona, June 1998
- [2.3] - European Club of ICOLD, “Uplift Pressures under Concrete Dams - Final Report” Report of the European Working Group, Proceedings of the ICOLD European Symposium “*Dams in a European Context*”, Geiranger, June 2001

3. SIGNIFICANT EXPERIMENTAL EXPERIENCES

Joints, discontinuities, fissures play a key role in the assessment of the safety against sliding, as the most likely place for sliding to occur is expected to be along relatively weak planar features. These include:

- joints and discontinuities in the foundation rock mass,
- concrete lift joints,
- concrete-to-rock contact surface.

The rock mechanics literature provides many evidences on the parameters ruling the shear response of joints and discontinuities in the foundation rock mass.

Comparatively less data are available dedicated to the actual properties of the dam-foundation contact surface and lift joints. Therefore, the Group decided to review significant experimental studies relevant to:

- concrete lift joints,
- concrete-to-rock contact surface,

highlighting the findings judged of main interest.

Attention was given to measured strength properties.

The review was concentrated on static loading conditions, not examining specific features associated to the dynamic loads.

The review was concentrated on conventional competent concrete. Materials other than conventional concrete (such as masonry, roller compacted concrete) were not included in the review, as well as weak concrete or concrete affected by important pathologies (such as: alkali-aggregate reaction).

This chapter is devoted to the reviewed experimental experiences, that is to the results of in situ and laboratory tests. How the data derived from tests should be interpreted and processed to be properly used in a dam safety assessment is examined in Chapter 4.

3.1 Examined studies

The main features of the studies carefully examined by the Working Group are given hereinafter.

The scope of the reviewed studies is synthesised in Fig 3.0.

Information about other interesting studies was derived from the examined studies (see complete list in “Bibliographic References”).

EPRI (USA) – Ref. 3.1

In 1992 a 3 years comprehensive study was completed by EPRI, providing data on basic parameters for the assessment of safety against sliding in concrete gravity dams. The study was carried out by Stone & Webster, with the co-operation of 14 important USA organisations.

The study was aimed to establish ranges of shear and tensile strengths, for both concrete-lift joints and dam-foundation contact surface. Natural joints in the foundation rock were outside the scope of the study.

EPRI reviewed available and reliable data from over 150 gravity dams. Furthermore, 17 host gravity dams were selected and specific investigations were carried out at each host dam. The host dams were built between 1912 and 1974, and range from 30 to 170 m in height. A variety of different rock foundations were represented, trying to encompass different types of concrete-to- rock interface.

20 SLIDING SAFETY OF EXISTING GRAVITY DAMS

The strength results were mainly determined by laboratory tests on specimens taken from the actual dams by coring. Some in-situ tests were also included.

ISMES (Italy) – Ref. 3.2

In late nineties an experimental programme was developed by ISMES, on behalf of ENEL, to examine the shear response of the concrete-to-rock contact surface.

Laboratory shear tests were carried out on large-scale concrete-to-rock specimens (contact area of the specimens: 0,5m²), to evaluate the scale effects and the influence of construction artefacts (interposition of cement milk) on the strength properties of the interface.

A limited attempt was also made to evaluate the influence of the rock type, by developing the test programme with two sets of rock basements.

École Polytechnique de Montréal (Canada) – Ref. 3.3

In 1998 the École Polytechnique de Montréal completed an applied research study, sponsored by the Canadian Electricity Association and Engineering Research Council of Canada, to evaluate the influence of the construction joints on the structural safety of existing concrete dams.

The study encompassed laboratory tests on lift joint specimens prepared in laboratory with different type of surface preparation, and numerical analyses.

Both static and seismic conditions were examined.

Pacelli et al. (Brazil) – Ref. 3.4

The mechanical properties of the lift joints and the influence of the joint treatment methods were discussed by Pacelli et al. in 1993, in an extended paper.

The results of experimental investigations carried out on 6 concrete gravity dams (5 Brazilian dams, 1 USA dam) were presented and discussed.

Lo et al. (Canada) – Ref. 3.5, 3.6, 3.7

In 1990-1994 several reports were published by Lo et al., containing the results of experimental tests for the evaluation of the strength parameters at the dam-foundation interface.

The tests were carried out to define a methodology for safety evaluation of concrete dams, as part of the Ontario Hydro Dam Safety Program.

Rocha (Portugal) – Ref. 3.8

In 1964, Rocha reported the results of a very extensive in-situ experimental programme carried out by the Laboratório de Engenharia Civil (Lisbon) to determine the strength properties of the dam-foundation interface.

Many large-scale shear tests were carried out at 6 different dam sites, involving different types of rocks.

Forrest, Bishoff (USA) – Ref. 3.9

In 2003 Forrest and Bishoff published a synthesis of experimental results about the tensile strength of lift joints and the influence of joint treatment.

The data were derived from experimental studies carried out by several USA authors and organizations.

3.2 Tensile Strength

The tensile strength can be determined by direct tension tests, splitting tests, bending tests.

Generally, direct tensile strength tests are most appropriate for planar features such as lift joints and concrete-to-rock contacts, because splitting tensile tests fail the core along a longitudinal plane which may not coincide with the feature to be tested.

Consensus is found in the technical literature about the fact that tensile strengths determined by the splitting method are usually greater and more scattered than those determined by the direct method. But direct tension tests are more difficult and not standardised. Therefore, splitting tests or bending tests are frequently used and correction factors (in the order of 0.9) are applied to estimate the direct tensile strength.

3.2.1 Concrete Lift Joints

- *EPRI – Ref. 3.1, 1992*

The strength data of concrete lift joints were obtained by direct tensile tests on specimens from cores taken at 14 dams.

In core samples from older dams, lift joints were readily discerned due to the presence of a layer of mortar or laitance. In dams where lift surfaces were cleaned before placing the next lift it was often difficult to see lift joints, and to identify them reference was made to the location of the core samples with respect to known lift dimensions.

In total, 107 specimens were tested, their diameter ranging from 5 to 25 cm. The age of the tested concrete was between 1 and 75 years.

Results (see Fig. 3.1):

- Average strength : 1.2 MPa (80-90% of the monolithic concrete)
- About 60% of the samples did not fail at the lift joints but elsewhere. In these cases the measured strength underestimates the actual lift joints strength.
- No evident correlation was found between the lift joints strength and the concrete age.

22 SLIDING SAFETY OF EXISTING GRAVITY DAMS

These results indicate that lift joints provide in general a significant tensile strength, with mean values comparable to those of the concrete mass.

▪ *PACELLI et al. – Ref. 3.4, 1993*

The results presented in Ref. 3.4 refer to numerous tests carried out at 6 concrete dams during their construction (from 1962 to 1988).

As an example, tensile strength data for Ilha Solteira project (27 samples diameter 25 cm, splitting tests), Jupia project (38 tensile flexural tests on blocks 40x40 cm) and Itumbiara project (undefined number of samples, splitting tests) are presented in Fig. 3.2a. In Fig. 3.2b are presented data for Itaipu project (36 samples diameter 25 cm, splitting tests).

The results discussed in Ref. 3.4 are relevant to different types of joint treatment: not treated, treated (mechanical method¹, wet sandblasting², greencutting³, high pressure water-blasting⁴), with or without mortar layer, plain or rough lift surface.

The tests were carried out on different types of samples (cored cylindrical samples, diameter: 20-25 cm; test blocks, area: 0.4x0.4 m) with different testing methods (splitting, direct, bending method). This must be carefully considered when comparing the various results, to avoid too punctual and detailed comparisons.

¹ Mechanical Method - Large rotary wire brushes mounted on rubber-tired equipment are employed. This method is sometimes combined with low-pressure water jet green cutting.

² Wet sandblasting - Employed on a very large number of dams throughout the world. It can be performed at any age of the concrete. More expensive than greencutting or waterblasting, it has the disadvantage that the disposal of sand after the clean-up interferes with and slows down other construction activities.

³ Greencutting - Early removal of mortar with an air-water jet at the relatively low pressure of 0.5 to 2 MPa, to expose a clean surface of sound concrete. It is performed 4 to 12 hours after placement, as the concrete approaches final set. If performed too early, it can loosen aggregate and remove too much sound mortar and cement paste. Also, it may not be possible to preserve the initially clean surface and prevent deposits of contaminants until fresh concrete is placed on it several days later, requiring additional clean-up immediately before the placement of a new lift.

⁴ High pressure water-blasting - A fan shaped jet operating at very high pressures (40 to 50 MPa) is employed. While the results are as good as those obtained by wet sandblasting, it is more economical and has the advantage that joint clean-up can be carried out just before the placement of new concrete (even 30 to 45 days after the old concrete was placed).

The Group felt it opportune to group the results reported in Ref. 3.4 in two main sections: "Not Treated" Lift Joints (only nominal clean up, with or without a mortar layer); "Treated" Lift Joints.

So doing, the results given in Ref. 3.4 can be so synthesised:

- "Not Treated Joints" : 40-80% of the monolithic concrete
(lowest percentages: absence of mortar layer)
- "Treated Joints" : 50-100% of the monolithic concrete
(lowest percentages: absence of mortar layer)

Considering that the absence of any joint treatment is not usual in the construction practice, it can be concluded from these results that lift joints have generally appreciable tensile strength.

About the various treatment methods, in Ref 3.4 it is concluded that high pressure water-blasting can be as effective as wet sand-blasting, and that an early and properly controlled greencutting can be almost as effective as water-blasting.

▪ *École Polytechnique de Montréal – Ref. 3.3, 1998*

A total of 8 specimens were prepared in laboratory with different joint treatment: water-blasted joint surface, untreated joint surface (cold joint, 3 days between concrete pours).

Three-point bending test were carried out to produce nearly horizontal cracks along the joint interface.

Results:

- Untreated joints : ~ 45% of the monolithic specimens
- Water-blasted joints : ~ 80% of the monolithic specimens

▪ *McColm et. al. – 1997, Ref. 3.10, 1997*

In Ref. 3.10 the results of laboratory tests on 100 mm samples are presented.

The joints were prepared in laboratory, as follows:

- No preparation;
- Water jet: exposing the aggregates of the bottom lift after 20 hours, pouring the next lift 4 hours later.
- Initial set: scarping the top 13 mm of the bottom lift after 5 hours, cleaning the surface, and pouring the next lift 19 hours later;

Complementary tests were carried out on small diameter (6 cm) lift joint cores extracted from an Ontario Hydro gravity dam.

Results:

24 SLIDING SAFETY OF EXISTING GRAVITY DAMS

- ‘No preparation’ joints : ~ 73% of the monolithic concrete;
- ‘Water jet’ joints : ~ 88% of the monolithic concrete;
- ‘Initial set’ joints : ~ 100% of the monolithic concrete.
- Complementary tests : ~ 48% of the monolithic concrete;

In Ref. 3.10 it is concluded from these results that the joint treatment has a significant influence on the tensile strength of lift joints, and that the strength of actual lift joints is significantly lower than that of joints prepared in laboratory.

▪ *Forrest et al. – Ref. 3.12, 2003*

In Ref. 3.12 a summary of tensile bending strength data is given. The data are taken from the experimental studies documented in Ref. 3.13- 3.14- 3.15- 3.16- 3.17- 3.18- 3.19- 3.20. The data were subdivided, according to the joint treatment method (no surface treatment, treated dry surface, treated wet surface).

The full summary of the results is reported in Fig. 3.3.

The results can be so synthesised:

- No treatment : 30-80% of monolithic concrete (average: 60%).
- Treated dry surface : 55-90% of monolithic concrete (average: 76%).
- Treated wet surface : 53-96% of monolithic concrete (average: 78%).

A significant tensile strength of lift joints, not far from that of the concrete mass, is confirmed by these results.

The range of the strength values is rather large because of the numerous studies reviewed. The individual values indicated in Fig. 3.3 have smaller variation ranges.

3.2.2 *Concrete-To-Rock Contact*

▪ *EPRI – Ref. 3.1, 1992*

In the EPRI investigations intact concrete-to-rock contacts were obtained by coring most of the time. Of the 74 cored concrete-to-rock contacts, ~ 80% were intact and ~10% were partially intact (for the remaining 10% no judgement could be made about their in situ condition). Therefore, a good number of specimens (23, from 5 dams) were used for direct tensile strength tests (core diameter: 5-12 cm, age of the concrete: 30-80 years).

Results (see Fig. 3.4):

- Average strength : 0.8 MPa
- Min-Max strength : 0.3 – 1.3 MPa

The measured average strength resulted larger than 50% of the strength of the monolithic concrete.

It may be concluded that concrete-to-rock contact joints are often intact and have significant tensile strength. However, it is outlined in Ref. 3.1 that concrete-to-rock contacts should not be assumed to be bonded unless supported by coring.

▪ *Lo et al. – Ref. 3.5- 3.6- 3.7, 1991-1994*

Concrete-to-rock contacts were cored at 30 dams (the oldest was 70 years old). In total, 79 intact contact samples were tested (direct tension tests). Of them, 37 failed along the contact, 42 elsewhere in the specimen (in these cases the measured strength underestimates the actual strength of the contacts). Considering the specimens that failed along the contact, the following results were obtained:

- Average strength : 0.9 MPa
- Min.-Max strength : 0.2 – 2.6 MPa

These results are very close to those obtained in EPRI study and confirm that dam-foundation interface can exhibit significant tensile strength.

3.3 Shear Strength

Samples containing a plane of weakness are described as "bonded" if they are intact and as "unbonded" if they are broken along the plane of weakness. The typical curves of the shear strength for bonded or unbonded samples are shown in Fig. 3.5. Peak shear strength is clearly determined during the shear tests. Residual strength determination is subjective, requiring interpretation on when it occurs, because laboratory data is not often as smooth as the curves in Fig. 3.5.

The shear strength of concrete-concrete joints and concrete-rock joints is usually expressed in terms of the Mohr-Coulomb failure criterion, referring to the shear strength lines defined by cohesion (c) and friction angle (Φ).

The actual relationship between peak strength and normal stress is curved, as shown in Fig. 3.6, because Φ is not constant. The Coulomb shear strength lines are straight-line approximation of the Mohr envelope and are dependent on the normal stress (σ_n).

3.3.1 Concrete Lift Joints

▪ *EPRI – Ref. 3.1, 1992*

Shear strength data of concrete lift joints given in Ref. 3.1 derive from 10 dams. The construction time of the dams ranges from 1906 to 1973.

All the tests were performed in 1978-1992 period, and presumably similar standard test procedures were used.

26 SLIDING SAFETY OF EXISTING GRAVITY DAMS

In total 223 specimens were tested (69 bonded; 154 unbonded).

Results for Peak Strength (69 bonded joints):

- Measured data : see Fig. 3.7
- Best fit line : $\Phi = 57^\circ$, $c = 2.1$ MPa
- Lower bound (90% of the data): $\Phi = 57^\circ$, $c = 1.0$ MPa

Results for Residual Strength (154 unbonded joints):

- Measured data : see Fig. 3.8
- Best fit line : $\Phi = 49^\circ$, $c = 0.5$ MPa (apparent cohesion).
- Best fit line (bi-linear) : $\Phi = 68^\circ$, $c = 0$ MPa, for $\sigma_n \leq 0.3$ MPa
: $\Phi = 49^\circ$, $c = 0.5$ MPa, for $\sigma_n \geq 0.3$ MPa
- Lower bound : $\Phi = 48^\circ$, $c = 0$ MPa

For unbonded samples an apparent cohesion is the result of small, high angle asperities on the surfaces being shared. It can result if linear failure envelope is used. At low normal stresses a bilinear failure envelope would be more appropriate.

▪ *Pacelli – Ref. 3.4, 1993*

In Ref. 3.44 are reported the results of shear tests carried out on 34 joint specimens from cores, diameter 25 cm, extracted from designated test blocks during the construction of Itaipu project.

Different treatment methods were applied to the test lift joints: wet sandblasting, greencutting, high pressure water-blasting, with or without mortar layer.

Results (see Fig. 3.9):

- ‘No treatment’ joints : ~ 40% of the monolithic concrete
- ‘Treated’ joints : 50 – 100% of the monolithic concrete
(lowest values: absence of mortar layer)

▪ *McLean and Pierce – Ref. 3.11, 1988*

Peak and residual shear strengths of the lift joints were evaluated examining the results of direct shear test carried out on samples extracted from USBR dams.

Results (best fit line):

- Peak strength : $\Phi = 55^\circ$, $c = 2.4$ MPa
- Residual strength : $\Phi = 47^\circ$, $c = 0.6$ MPa

It is concluded in Ref. 3.11 that bonded lift joints had a peak strength nearly identical to the monolithic concrete ($\Phi = 58^\circ$, $c = 2.5$ MPa).

3.3.2 Concrete-To-Rock Contact

- *Rocha - Ref. 3.8, 1964*

Within the experimental programme carried out by LNEC, as for the concrete-to-rock bond about 70 blocks of concrete (70x70x35 cm) were cast at 6 different dam sites, on different types of rocks (altered granite, several types of shale, sandstone). The in situ tests were carried out in entirely analogous conditions.

Many of the rocks involved in the tests presented a marked alteration.

Results (peak strength):

- Measured data : see table in Fig. 3.10
- Range of Φ : $\Phi = 53^\circ - 63^\circ$
- Range of c : $c = 0,1 - 0,7$ MPa

Most of the collapse was dominated by the sliding in the foundation rock along surfaces parallel to the dam-foundation interface. That was related to the low strength of the rock mass and to the irregularity of the surfaces on which the concrete samples were cast. Consequently, the measured strength parameters underestimate the actual strength of the concrete to rock bond.

- *Link – Ref. 3.12, 1969*

An extensive tabulation of measured rock and concrete-to-rock strength was presented by Link in 1969.

When values related to soft marls, highly weathered rock and rock joints or bedding planes were eliminated, the following values resulted for the concrete to rock bond.

Results:

- Range of Φ : $\Phi = 45^\circ - 52^\circ$
- Range of c : $c = 0.1 - 3.0$ MPa

- *LO, et al. – Ref. 3.5- 3.6- 3.7, 1991 -1994*

The shear strength for both bonded and unbonded concrete-to-rock contacts was evaluated testing samples taken from dams.

The age of the examined dams varied from 15 to 80 years.

On bonded intact concrete-rock samples, a total of 10 triaxial compression tests, 13 triaxial extension tests and 45 direct tension tests were carried out. The adopted testing procedure enabled the direct determination of the cohesion from the envelope based on triaxial compression and extension tests, without extrapolation (as is necessary in conventional triaxial or direct shear tests).

On unbonded concrete-rock contacts, a total of 38 tests were carried out, and the residual strength (basic friction angle) was evaluated.

The tests involved several different types of rocks, examined in the normal stress range 0.1 - 1.4 MPa.

Results for peak strength:

- Typical reported values: $\Phi = 62^\circ$, $c = 2.2$ MPa
- The results were not too sensitive to the rock type

Results for residual strength:

- Reported values: : $\Phi = 32-39^\circ$ (average: 37°)

From these results it is underlined in Ref. 3.5 that the concrete-rock contact surface is not necessarily the most critical failure surface, as it can sustain significant tension, and its shear strength possesses an inherent cohesion component.

▪ *EPR – Ref. 3.1, 1992*

Direct shear strength data on concrete-to-rock contacts were obtained for 18 dams. The construction period of the dams varied from 1912 to 1965.

All lab tests were performed in 1978-1992 period, and presumably similar standard test procedures were used. The data included two large scale in situ tests. Data encompassed eight foundation rock types.

In total, 65 samples were tested (diameter: from 5 to 15 cm). Both peak and residual shear strengths were evaluated.

Results for Peak Strength:

- | | |
|--------------------------------|--|
| Best fit lines | : see table in Fig 3.11 |
| ○ Peak friction angles | : $\Phi = 54^\circ - 68^\circ$ |
| ○ Cohesion for most rock types | : $c = 1.3-1.9$ MPa (average: 1.7 MPa) |
| ○ Cohesion for shale | : $c = 0.1$ MPa |
| Lower bound lines | : see table in Fig 3.11 |
| ○ Peak friction angles | : $\Phi = 53^\circ - 68^\circ$ |
| ○ Cohesion for most rock types | : $c = 0.3-1.1$ MPa (average: 0.6 MPa) |
| ○ Cohesion for shale | : $c = 0$ MPa |

These results point out the difference between the cohesion values measured for the shale and those measured for all the other types of rocks. The measured cohesion values for the other types of rock are rather homogeneous, without large differences. As an example of the full set of the experimental results, the results for the sandstone (15 tests) and the granite (6 tests) are reported in Fig. 3.12 and 3.13.

In the evaluation of the results reported in Fig. 3.11, it must be noted the quite variable number of tests for the various types of rock.

Results for Residual Strength:

- | | |
|----------------|------------------------|
| Best fit lines | : see table in Fig. 11 |
|----------------|------------------------|

- Peak friction angles : $\Phi = 24^\circ - 39^\circ$
 - Cohesion : $c = 0 - 0.2 \text{ Mpa}$ (average: 0.1 MPa)
- Lower bound lines : see table in Fig. 11
- Peak friction angles : $\Phi = 13^\circ - 32^\circ$
 - Cohesion : $c = 0 \text{ MPa}$

Some apparent cohesion was found even under residual conditions. It is the result of the small, high angle asperities on the surfaces being shared. In an ideal zero normal stress test, the opposing shear surfaces would tend to ride up the asperities and not shear them. The resulting friction angle would be very high and the cohesion would be zero.

For both peak and residual strength the results of the two available large scale in situ tests were in the upper bound of the data (grater than the lab tests results).

▪ *ISMES - Ref. 3.2, 1999*

Laboratory shear tests were run on 16 large scale specimens, to evaluate the influence of construction artefacts (extra bonding due to interposition of cement milk).

Two rock basements (a mica-schist, an ortho-gneiss) were examined.

Results (Fig. 3.14):

- Peak strength was not strongly influenced by the type of rock, while residual strength did.
- Peak strength was lower when films of adhesive material (cement milk) were not used, while residual conditions did not.

These results pointed out that the peak strength of the interface was significantly influenced by the bonding established by the cement milk.

The peak strength occurred at shear displacements in the order of 0.02% of the contact length, followed by a sharp softening and a dilatancy increase.

A clear residual condition was observed at a relative displacement of 2%.

The observed sharp peak conditions were due to an effective locking of the rock to concrete, enhanced by the interposition of the cement milk.

Observation of joint surfaces after the tests showed a significant amount of concrete left on the rock face of the joint.

3.4 Remarks / Comments

- A surprisingly large number of important experimental experiences have been retrieved. They were carried out in various Countries (USA, Canada, Brazil, Portugal, Italy), over a large time span (about 40 years). That underlines the continuous interest of the subject and its complexity too.

The chronological sequence of the examined studies is the following:

- 1964 : Rocha
 - 1969 : Link
 - 1988 : McNeal et al.
 - 1992 : EPRI
 - 1993 : Pacelli et al.
 - 1990-94 : Lo et al.
 - 1997 : McColm et al.
 - 1998 : École Polytechnique de Montréal
 - 1999 : ISMES
 - 2003 : Forrest et al.
- EPRI study has the widest scope. It examined both the tensile and the shear strength parameters, of both concrete lift joints and concrete-to-rock contacts. The other studies are concentrated on concrete lift joints only (Pacelli et al., McColm et al., École Polytechnique de Montréal, McNeal and Pierce., Forrest et al.), or concrete-to-rock contacts only (Rocha, Link, Lo et al., ISMES) - See Fig. 3.0.
 - Some studies are characterised by a very large number of tests (i.e.: EPRI, Rocha, Link). Some others are characterised by a smaller number of tests and more specific aims (i.e.: École Polytechnique de Montréal, Pacelli et al., ISMES).
 - Some studies were mostly based on samples taken from dams in operation, therefore including possible ageing effects (i.e.: EPRI, Lo et al., McNeal and Pierce). Others examined, mostly or solely, samples taken during the dam construction, or samples prepared in laboratory.
 - Some experiences were based on large scale test, in situ (Rocha) or in lab (ISMES).
 - Data and information given by these experiences are valuable, considering that the experimental evaluation of the strength parameters for a specific dam may be unavoidably constrained by obvious limitations. The available experimental experiences represent therefore a valuable tool for preliminary estimates of strengths, for improving confidence in limited site data and for estimating the benefits of specific site investigations (as pointed out in Chapter 2).

3.4.1 Concrete lift joints

Tensile strength

All the examined experiences point out that that lift joints provide in general a significant tensile strength. For lift joints with some type of treatment (as usual in dam construction) the tensile strength always was found to be in a range of 50-100% of the tensile strength of the monolithic concrete, and in most cases not far from it.

Shear strength

Also the shear strength was always found to be significant, with cohesion values frequently in the order of 1–2 MPa. It must be reminded that even a small cohesion can have a strong influence in the sliding safety assessment.

3.4.2 Dam-foundation interface

The experiences pointed out that many of the in situ cored concrete-to-rock contacts were found intact (bonded).

Tensile strength

Concrete-to-rock contact showed significant tensile strength, in the order of 0.8–1.0 MPa, larger than 50% of the strength of the monolithic concrete.

Shear strength

Most of the experiences pointed out that concrete-to-rock contact surface is not necessarily the most critical failure surface. It can sustain significant shear stresses and, where bonding is effective, the strength of concrete-to-rock contact may lead to a failure surface within the foundation rock (as experienced in most of the tests when weak rock was involved). Such strength may therefore cause the minimum factor of safety be calculated for sliding along natural joints in the foundation rather than along the dam-foundation interface. Considering the extension of the dam-foundation interface, even small values of cohesion may provide a significant contribution to the tangential resistance. A significant influence of the extra-bonding due to the interposition of cement milk between the foundation surface and the concrete was pointed out, where the cement paste is able to adhere to the underlying rock.

3.5 Bibliographic References

- [3.1] - Stone & Webster Engineering Corporation, "*Uplift Pressures, Shear strength and Tensile Strengths for Stability Analysis of Concrete Gravity Dams*", EPRI TR-100345, Project 2917-05, August 1992.
- [3.2] - ISMES, "La verifica allo scorrimento di dighe a gravità: Riflessioni da evidenze sperimentali", internal report RAT-STR-2016, 1999.
- [3.3] École Polytechnique de Montréal, "Structural safety of existing concrete dams: Influence of construction joints", Canadian Electricity Association contract 9032 G 905, April 1998
- [3.4] Pacelli, W.A., Andriolo, F.R., Sarkaria, G.S., "Treatment and performance of construction joints in concrete dams", Water Power and Dam Construction, November 1993

- [3.5] - Lo, K.Y., Ogawa, T., LuKajic, B., Smith, G.F., Tang, J.H.K., "The evaluation of stability of existing concrete dams on rock foundations and remedial measures", 17th ICOLD Congress, 1991
- [3.6] - Lo, K.Y., LuKajic, B., Wang, S., Ogawa, T., Tsui, K.K., "Evaluation of strength parameters of concrete-rock interface for dam safety assessment", Canadian Dam Safety Conference, Toronto, 1990
- [3.7] - Lo, K.Y., Grass, J.D., "Recent experiences with safety assessment of concrete dams on rock foundation", Canadian Dam Safety Conference, Winnipeg, Manitoba, 1994
- [3.8] - Rocha, M., "Mechanical Behaviour of Rock Foundations in Concrete Dams", 8th ICOLD Congress, May 1964
- [3.9] - Forrest, M.P., Bishoff, J.A., "Tensile strength of lift joints in concrete dams", 21th ICOLD Congress, Q82-R24, 2003
- [3.10] - McColm, E.J., Ko, P.K., Mukherjee, P.K., "Evaluation of horizontal construction joints in massive concrete hydraulic structures", CDSA/CANCOLD Joint Dam Safety Conference, Montreal 1997.
- [3.11] - McLean, F.G., Pierce J.S., "Comparison for joint shear strength for conventional and roller compacted concrete", RCC II, Proc. Conf. Sponsored by Const, Geotech. Eng., Mat. Eng. Division of ASCE, San Diego, 1988
- [3.13] - Link, H., "The sliding stability of dams", Water Power, March-April-May 1969, pp. 99-103, 135-139, 172-179.
- [3.14] - Davis R.E.; Davis H.E.; "Bonding of new concrete to old at horizontal construction joints", Journal of the ACI (Proceedings), Detroit, MI, Vol. 30, May-June 1934.
- [3.15] - Waters T., "A study of the tensile strength of concrete across construction joints", Magazine of Concrete Research, Cement and Concrete Association, London, England, Vol. 6, No. 18, 1954
- [3.16] - Tynes W.O., "Investigation of methods of preparing lift joints in concrete", Technical Report no: 6-518, Report 1, US Army Engineer Waterways Experiment Station, Vicksburg, Mississippi, 1959.
- [3.17] - US Army Corps of Engineers, "Investigation of methods of preparing horizontal lift joints in concrete", Technical Report no: 6-518, Report 2, US Army Engineer Waterways Experiment Station, Vicksburg, Mississippi, July 1963.
- [3.18] - Houghton D.L.; Hall D.J.; "Elimination of grout on horizontal construction joints at Dworshak dam", Journal of the ACI (Proceedings), Detroit, MI, Vol. 69, March 1972.
- [3.19] - Tynes W.O.; McCleese W.F., "Investigation of methods of preparing horizontal lift joints in concrete", Technical Report no: 6-518, Report 4, US Army Engineer Waterways Experiment Station, Vicksburg, Mississippi, August 1973.
- [3.20] - Tarbox G.S.; Dreher K.J.; Carpenter L. R.; "*Seismic analysis of concrete dams*", 13th ICOLD Congress, Q51-R11, 1979

Study	Publication date	Lift joints		Dam-foundation interface	
		Tensile strength	Shear strength	Tensile strength	Shear strength
Rocha	1964				
Link	1969				
McLean et al.	1988				
EPRI	1992				
Pacelli et al.	1993				
Lo et al.	1994				
McColm et al.	1997				
Poly. Montreal	1998				
ISMES	1999				
Forrest et al.	2003				

Fig. 3.0 - Examined studies

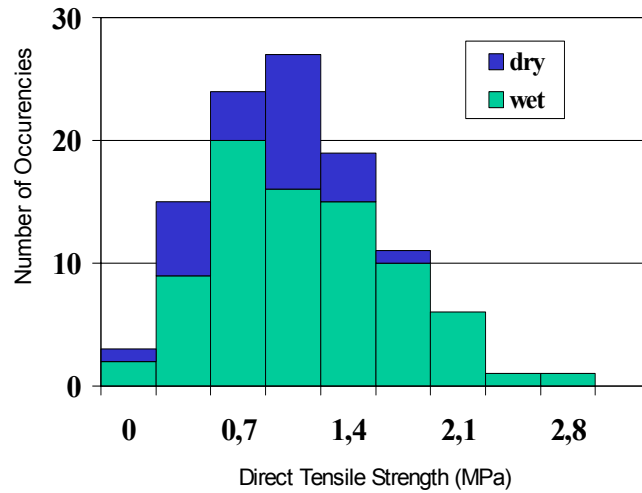

Fig. 3.1: Concrete lift joints – Tensile strength (from Ref. 3.1)

34 SLIDING SAFETY OF EXISTING GRAVITY DAMS

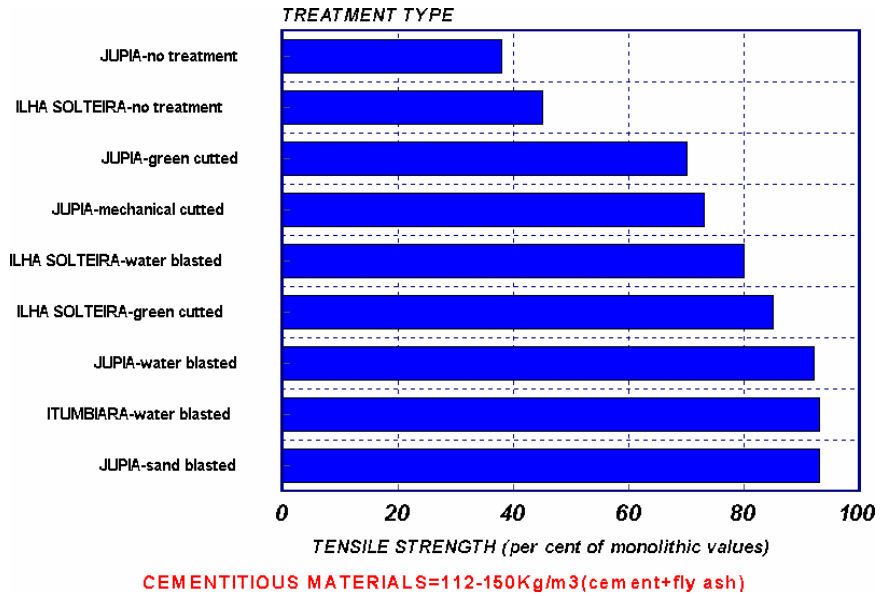

Fig. 3.2a: Concrete Lift Joints – Tensile Strength (from Ref. 3.4)

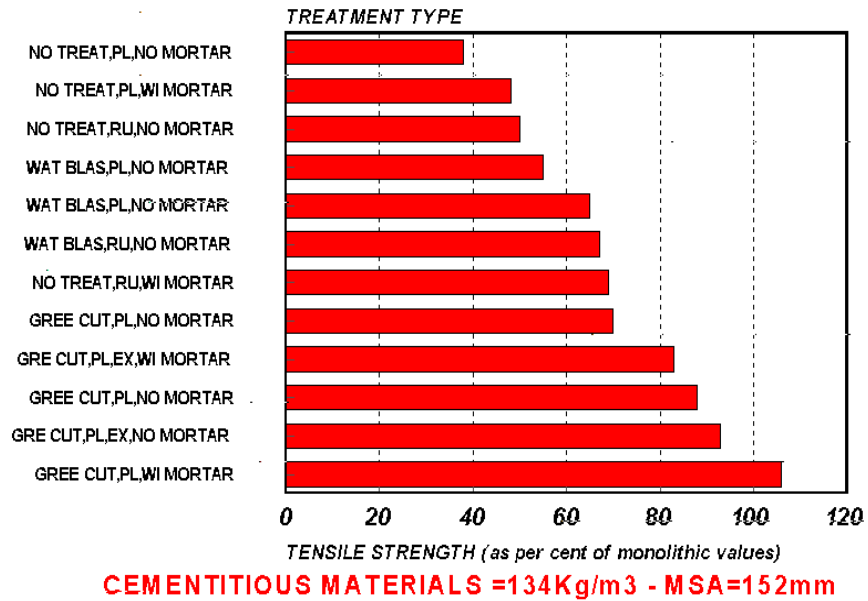

Fig. 3.2b: Concrete Lift Joints – Tensile Strength (Itaipu, from Ref. 3.4)

AVERAGE TENSILE BENDING STRENGTH OF LIFT JOINTS : REDUCTION FACTORS							
	A	B	C	D	E	F	G
Untreated Surface							
Young joint, laitance left in place	-	0,45	0,31	-	-	-	-
Dry sand thrown on fresh concrete, then washed off	-	0,41	-	-	-	-	-
Old dry joint	-	-	-	0,74	-	-	-
Young joint, concrete dried out	-	0,78	-	-	-	-	-
Old wet joint	-	-	-	0,83	-	-	-
Laboratory-desiccated concrete	-	0,86	-	-	-	-	-
Treated dry concrete - Joint Preparation							
Wire-brushed, hand compaction	0,55	0,57	-	-	-	-	-
Wire-brushed, vibrated	0,75	-	-	-	-	-	-
Dry sand-blasted	-	-	-	-	-	-	0,87
Wire-brushed, dried concrete	-	0,76	-	-	-	-	-
High pressure jet, dried concrete	-	-	-	-	0,80	-	-
Young dry joint with thick flowed mortar	-	-	-	0,88	-	-	-
Young dry joint with thin broomed mortar	-	-	-	0,90	-	-	-
Young dry joint with thin flowed mortar	-	-	-	0,86	-	-	-
Young dry joint with thick broomed mortar	-	-	-	0,72	-	-	-
Old dry joint with thick broomed mortar	-	-	-	0,78	-	-	-
High pressure jet with mortar, dry joint	-	-	-	-	0,72	-	-
Treated wet concrete - Joint Preparation							
Air water jet, hand compaction	0,66	-	-	-	-	-	-
Air water jet, vibrated	0,83	-	-	-	-	-	-
Wet sandblasting, laitance removed	-	0,53	0,71	-	-	-	-
Wet sandblasting, aggregate exposed	-	0,78	-	-	-	-	-
High-pressure jet	-	-	-	-	0,75	0,73	-
Air-water jet, young joint thick broomed mortar	-	-	-	0,96	-	-	-
Air-water jet, young joint with thick flowed mortar	-	-	-	0,64	-	-	-
Air-water jet, young joint with thin broomed mortar	-	-	-	0,85	-	-	-
Air-water jet, young joint with thin flowed mortar	-	-	-	0,94	-	-	-
Air-water jet, old joint with thick broomed mortar	-	-	-	0,94	-	0,92	-
Hig pressure jet, with mortar	-	-	-	-	0,70	-	-

REFERENCES: A - Davis and Davis (1934), B - Waters (1954), C - Tynes (1959), D - US Army Corps of Engineers (1963), E - Tynes & McCleese (1973), F- Houghton and Hall (1972), G - US Bureau of Reclamation, Tarbox, Dreher and Carpenter (1979)

Fig. 3.3: Concrete Lift Joints – Tensile Strength (from Ref. 3.9)

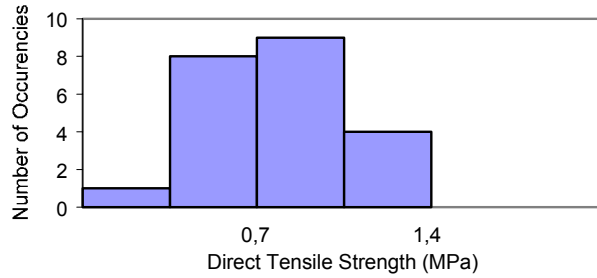

Fig. 3.4: Concrete-to-rock contact. Tensile strength (from Ref. 3.1)

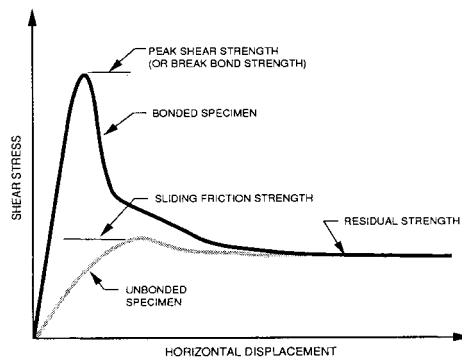

Fig. 3.5: Shear strength for bonded or unbonded samples

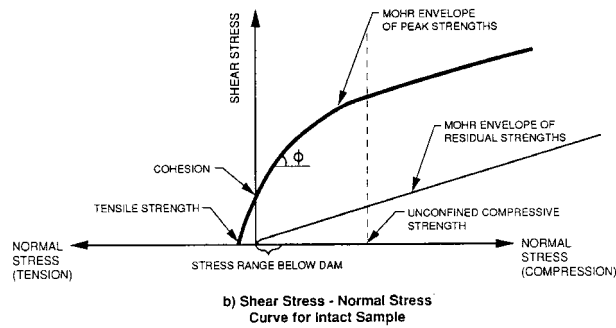

Fig. 3.6: Relationship between shear strength and normal stress

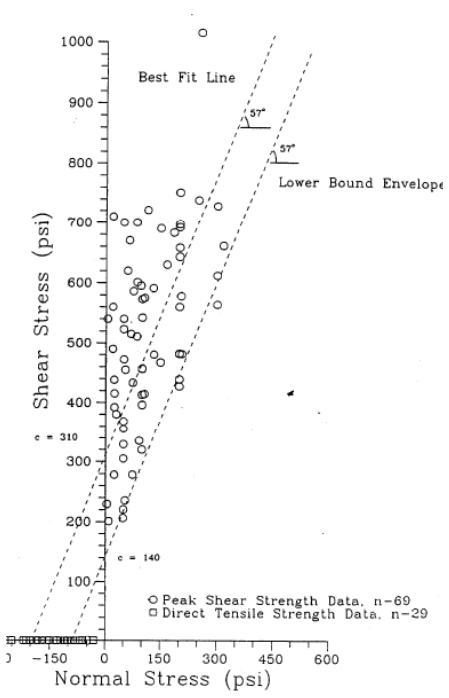

Fig. 3.7: Concrete lift joints. Peak shear strength (from Ref. 3.1)

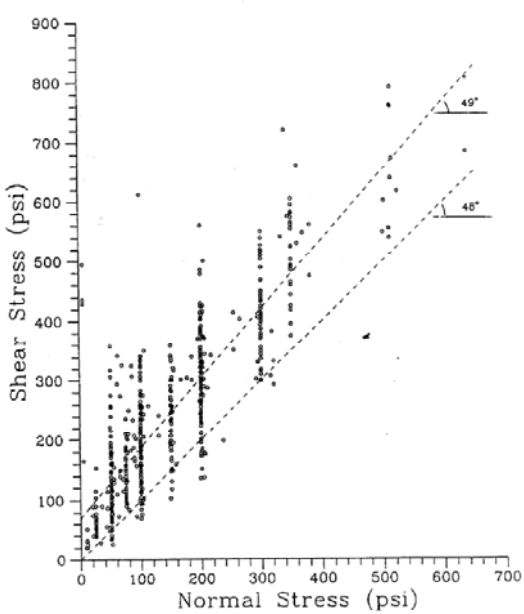

Fig. 3.8: Concrete lift joints. Residual shear strength (from Ref. 3.1)

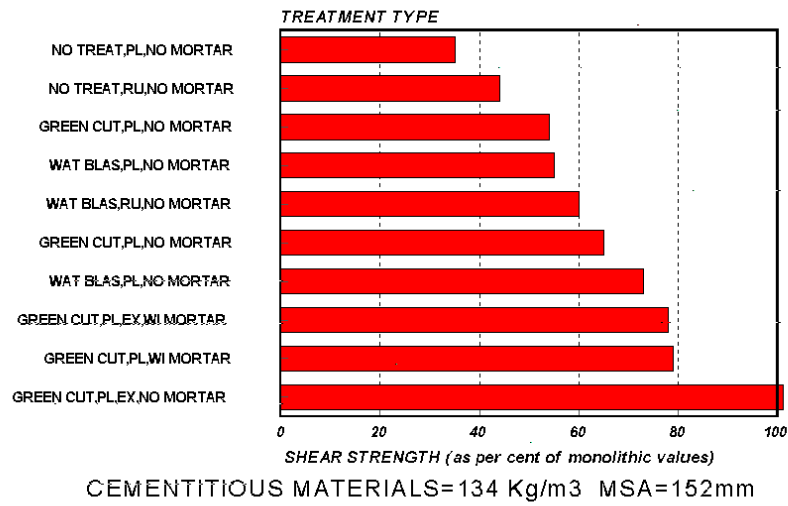

Fig. 3.9: Concrete Lift Joints – Shear strength (Itaipu, from Ref. 3.4)

Peak strength

Rock-type / Dam	Number of tests	Cohesion	Friction angle
		[MPa]	[°]
Altered Granite / <i>Alto Rabagao</i>	8	0,2	56
Shale / <i>Bemposta</i>	8	0,2	60-63
Shale / <i>Valdecañas</i>	3	0.4	62
Shale / <i>Miranda</i>	16	0,4-0.7	60-62
Shale / <i>Alcantara</i>	28	0,1	56
Sandstone / <i>Cambambe</i>	4	0.2	53

Fig. 3.10: Concrete-to-rock contact.
Shear strength (from Ref. 3.8)

Peak Strength

Contact Rock-type	Number of tests	Best fit			Lower bound	
		Cohesion	Friction angle	Correlation coefficient.	Cohesion	Friction angle
		[MPa]	[°]	[-]	[MPa]	[°]
Granite	6	1,26	54	0,84	0,66	53
Granite – gneiss	4	1,30	57	0,87	0,48	57
Limestone/dolomite	9	1,92	68	0,49	1,14	68
Phyllite	3	1,66	62	0,84	0,48	62
Sandstone	15	1,79	65	0,80	0,34	65
Shale	9	0,12	60	0,79	0	48

Residual Strength

Contact Rock-type	Number of tests	Best fit			Lower bound	
		Cohesion	Friction angle	Correlation coefficient.	Cohesion	Friction angle
		[MPa]	[°]	[-]	[MPa]	[°]
Granite	6	0,08	35	0,93	0	32
Granite – gneiss	4	0,03	34	0,99	0	31
Limestone- dolomite	12	0,12	35	0,58	0	23
Phyllite	5	0	39	0,89	-	-
Sandstone	46	0,18	29	0,60	0	27
Shale laboratory	13	0	34	0,75	0	13
Siltstone	13	0,11	24	0,83	0	22

Fig. 3.11: Concrete-to-rock contact.
Peak and Residual Shear Strength (from Ref. 3.1)

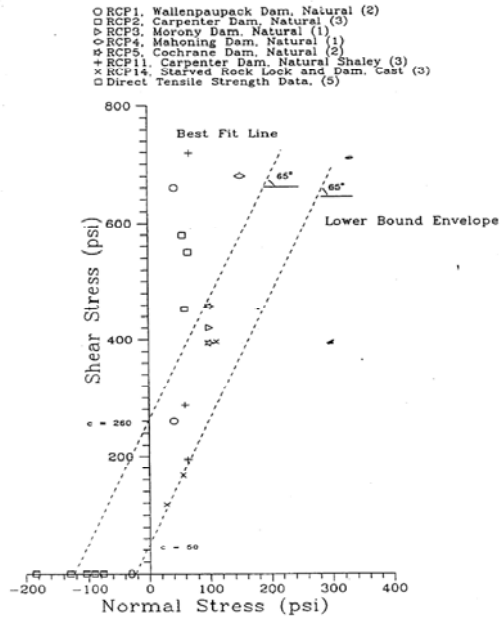

Fig. 3.12: Concrete-to-rock contact. (Sandstone) - Peak Shear Strength (from Ref. 3.1)

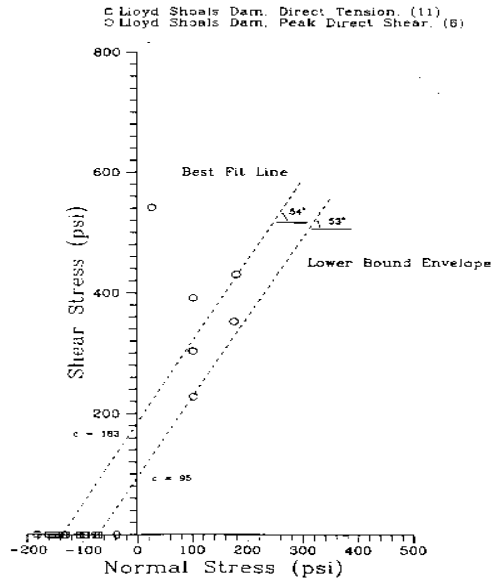

Fig. 3.13: Concrete-to-rock contact. (Granite) - Peak Shear Strength (from Ref. 1)

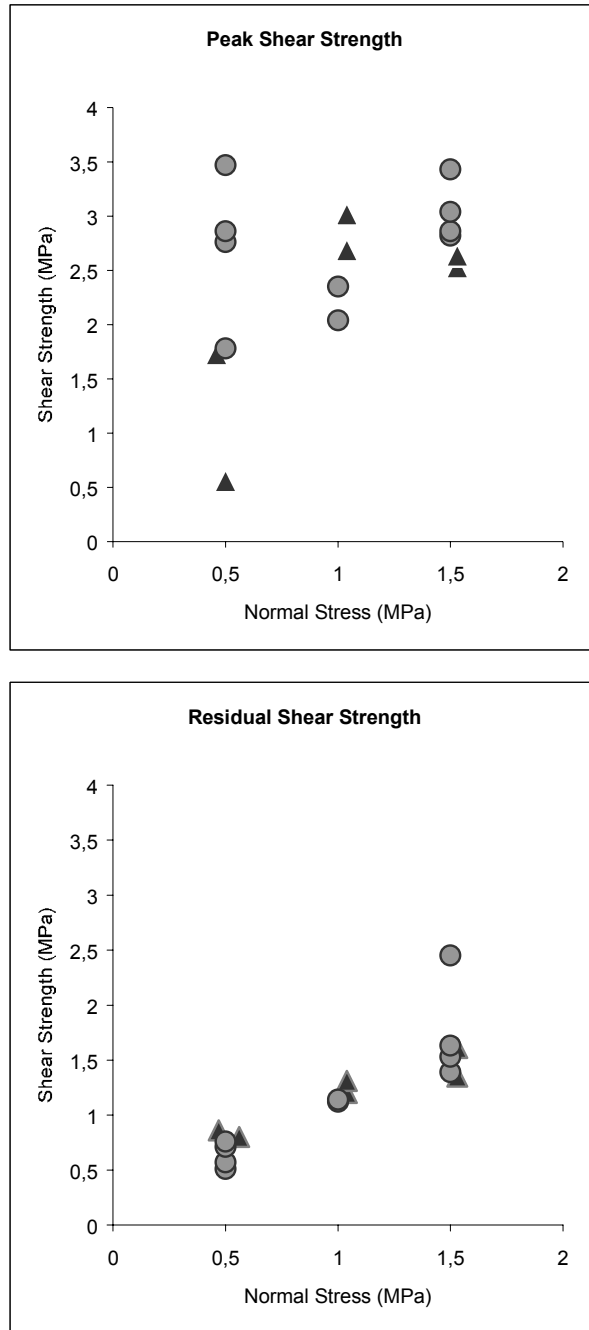

Fig. 3.14 – Concrete-to-rock contact (source: ISMES).
 Peak and Residual Shear Strength
 With cement milk (circles), Without cement milk (triangles).

42 SLIDING SAFETY OF EXISTING GRAVITY DAMS

4 TECHNIQUES FOR THE SAFETY ASSESSMENT

Sliding is indeed an ultimate state of degradation of the structural response of the dam-foundation system, mainly influenced by the discontinuities (joints) located within the foundation, in the concrete mass (lift joints) or at the concrete to rock contact surface.

Well-consolidated traditional methods (“limit equilibrium approach”) use this limit condition (sliding) as a design basis and establish appropriate safety margins to incorporate the sources of uncertainty embedded in the method. The safety criteria established by the limit equilibrium approaches rely on the shear carrying capacity of the given interface. Some methods define the ‘resisting’ length of such interface as that not subjected to tractions. The shear capacity of the interface is openly related in many codes to the frictional properties of the interface itself. The tensile capacity is due to the tensile strength of the ligament.

The limit equilibrium approach is described in 4.1

More recently, methods able to study the structural behaviour from the linear reversible response (service conditions) to the non-linear irreversible one (limiting states) have become available (“deformable body approach”). They are mostly operational in finite element codes. They are suited to describe the actual structural response and to establish a mathematical reference model for records recovered by the monitoring net installed at the dam. These approaches are described in Section 4.2

The deformable body approach is fully exploited only if a higher detail in the description of model properties is available respect to the design situation. The detail concerns the structural layout, to capture the “as built” condition, the actual physical and mechanical properties of the materials (concrete, foundation, interfaces - irrespective whether they are fractures or joints), and the loading sequence.

The above aspects are addressed in 4.3, 4.4, and 4.5.

It is a general question which criteria must be adopted to retrieve representative material properties from experimental data. Scale effects are invoked for all material properties involved in the modelling.

Some insight into this aspect is given in 4.6.

In addition to a number of relevant contributions in technical literature, a Benchmark Workshop was recently carried out on the above subject, by the Numerical Committee of ICOLD, providing instructive evidences of the actual potentials of such methods.

This is commented in 4.7.

Some general remarks are then given in 4.8

4.1 Limit equilibrium approach

To evaluate the safety against sliding the most popular, used and accepted methods model the dam (or the dam-foundation system) as a rigid body allowed to slide along its base or lift joints, or along critical surfaces embedded in the foundation rock.

Safety against sliding is evaluated by assessing the balance offered to loads by the resisting forces mobilised along the sliding surface.

The sliding surface is defined on the basis of the judgement about the location of the most probable ones.

The simplest methods ask only for the evaluation of the equilibrium of tangential forces along the entire sliding surface. Some others, that are widely accepted as well, differentiate the part of the sliding surface where normal stresses are compressive from that where tensile stresses exceed the allowable ones (Cracked Base analysis). To evaluate which is the portion of the sliding surface not contributing to the shear resistance, the dam cross section is usually examined as a cantilever beam fully restrained at the base. The allowed tensile strength rules such evaluation. The safety-oriented judgement about strength properties is the critical aspect of these methods, which are otherwise quite simple to apply.

The limit equilibrium methods have the advantage that they allow for a straightforward formal incorporation of the uplift pressure as an external load.

In practice, reference is often made to plane structural schemes and to a collapse criterion based on the Mohr Coulomb constitutive model.

Locally, for each point of the potential sliding surface, the following relationship holds true:

$$\tau \leq \frac{(c + \sigma_n \cdot \operatorname{tg} \varphi)}{\nu} \quad (1)$$

where:

- c : cohesion;
- σ_n : normal stress to the sliding surface;
- φ : friction angle.
- τ : tangential stress
- ν : safety factor

In conclusion, to discard any possibility of local collapse, the tangential stress acting over the potential sliding surface should not exceed the available shear strength.

44 SLIDING SAFETY OF EXISTING GRAVITY DAMS

Global safety assessments are performed by integrating σ_n and τ over the potential sliding plane.

For gravity dams, the integrated safety condition is expressed as:

$$T \leq \frac{(cA + N \cdot \tan\phi)}{v} \quad (2)$$

where:

- T, N : forces acting parallel and normal to the surface under analysis;
- A : contact area.

To derive expression (2) from expression (1) is not trivial as it may appear. Expression (2) in fact considers that, at collapse, the ultimate capacity is achieved at each point of the sliding surface. This holds true in ductile materials, but the experimentally observed response of a sliding surface is seldom fully ductile and, in general, may be described as semi-brittle.

Once the yielding threshold is attained, parameters ruling the structural capacity of the sliding surface (peak strength parameters) decay while strain progresses (softening response). At larger strains, they tend to reach a constant value achieving the so-called ultimate or residual values.

Typical results of strain-controlled confined shear test are shown in Fig. 4.1, representing “shear stress vs. shear strain” together with “vertical displacement vs. shear strain”. The diagrams reported in Fig. 4.1 come from a test on a rock-concrete interface, but similar conclusions can be drawn for discontinuities in rock and in concrete.

It is interesting to note that considerable peak shear strength is opposed by the interface, respect to that related to ultimate conditions. Such peak resistance occurs at small strains (order of ‰), respect to the residual strength (order of %).

Shear carrying capability degenerates towards the residual conditions, and the degeneration is characterised by a sharp softening.

Shearing is accompanied by dilatancy, which has important consequences in ‘confined’ problems, while for unconfined sliding mechanisms (such as the sliding mechanism of gravity dams) it is anticipated as less important.

The selection of prudential but realistic values requires an adequate investigation of the actual conditions of the specific dam (see Chapter 2).

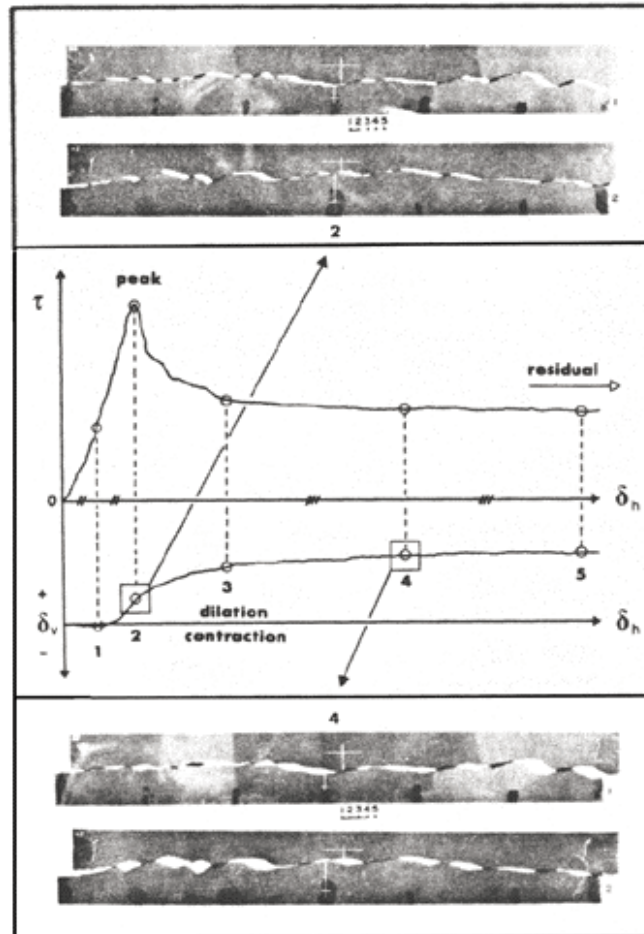

Fig. 4.1: Measured response of large rock-concrete contacts [Barton, 1976]

Adequate scale effects on material parameters should be considered, depending on specimen's dimensions and joint properties (see 4.7).

Cohesion is usually the most uncertain strength parameter. On the other hand, even a very small cohesion can provide significant contribution to the overall shear strength.

4.1.1 Hoek and-Brown's strength criterion

This criterion is popular to support stability checks within rock foundations, in that it can incorporate all sorts of data/properties necessary to describe the shear strength of a rock mass.

This criterion describes the observed non-linear dependency of the shear strength domain on confining stress. It is expressed in terms of principal

stresses⁵ and is linked to empirical geological observations by means of rock mass classification schemes, as the Rock Mass Rating (RMR) by Bieniawski (Fig. 4.2).

The Generalised Hoek and Brown criterion links material constants to:

- The Geological Strength Index (GSI), to encompass problems encountered in applying the RMR classification for weak to very weak rock masses.
- A disturbance factor D, which represents the degree of disturbance to which the rock mass has been subjected by blast damage and stress relaxation.

A constitutive elastic model complements the material model, where, again, the rock mass modulus of deformation depends on the compressive strength and GSI and D factors.

The strength criterion can be translated in terms of normal and shear stresses at failure. Cohesion and friction angle of the Mohr Coulomb criterion can be derived, once the stress range for the matching is defined⁶.

$$^5 \sigma_1' = \sigma_3' + \sigma_{ci} \left(m_b \frac{\sigma_3'}{\sigma_{ci}} + s \right)^a,$$

where σ_1' and σ_3' are the major and minor effective principal stresses at failure; σ_{ci} is the uni-axial compressive strength of the intact rock material;

a, m and s are material constants, where s=1 is for intact rock.

$$m = m_i \exp\left(\frac{RMR - 100}{28}\right) \quad s = \exp\left(\frac{RMR - 100}{9}\right)$$

a=0.5 for most hard rocks.

⁶ This is achieved by defining the maximum principal stress values σ'_{3max} (confining stress) of interest. By expressing the Mohr Coulomb criterion in terms of principal stresses:

$$\sigma_1' = \frac{2c' \cos \phi' + 1 + \sin \phi'}{1 - \sin \phi'} \sigma_3'$$

and by defining $\sigma_{nc} = \sigma'_{3max} / \sigma_{ci}$ the following relations are obtained :

$$\phi'' = \sin^{-1} \left(\frac{6am_b (s + m_b \sigma'_{3n})^{a-1}}{2(1+a)(2+a) + 6am_b (s + m_b \sigma'_{3n})^{a-1}} \right)$$

$$c' = \frac{\sigma_{ci} \left[(1+2a)s + (1-a)m_b \sigma'_{3n} \right] (s + m_b \sigma'_{3n})^{a-1}}{(1+a)(2+a) \sqrt{1 + \left[\frac{6am_b (s + m_b \sigma'_{3n})^{a-1}}{2(1+a)(2+a) + 6am_b (s + m_b \sigma'_{3n})^{a-1}} \right]^2} / ((1+a)(2+a))}$$

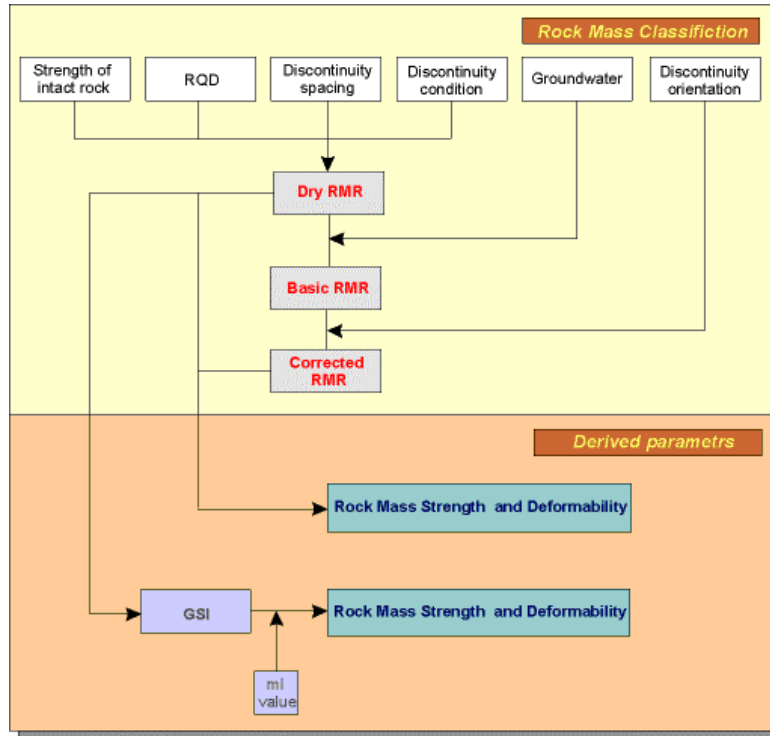

Fig. 4.2: Data which support the calculation of the indexes RMR and GSI.

4.1.2 Burton's strength criterion

To explicitly capture the non-linear dependence of strength on stress and joint properties, the well-known criterion of Barton (Ref. 4.1, 4.2) is recognized as an important reference.

Methods for directly incorporating the size effects within the Barton approach are operational in the geo-mechanical practice. They allow to represent the shear strength development (τ_p) with normal stress (σ), as follows, for peak and residual strength:

- $\tau_p = \sigma \tan (JRC_p \times \log_{10} (JCS / \sigma) + \phi_b) + c$
- $\tau_r = \sigma \tan (JRC_r \times \log_{10} (JCS / \sigma) + \phi_b)$

- JRC_p : peak Joint Roughness Coefficient;
- JRC_r : residual Joint Roughness Coefficient;
- JCS : Joint wall Compressive Stress;
- ϕ_b : basic friction angle, for some Authors coincident with the residual one;
- c : cohesion.

Empirical expressions for scaling the values of JRC and JCS from laboratory size (L_o), to in situ block size (L_n), are the following:

- $JRC_n = JRC_o(L_n/L_o) - 0.02JRC_o$
- $JCS_n = JCS_o(L_n/L_o) - 0.03JRC_o$

where subscripts 'o' and 'n' refer to laboratory and in situ conditions.

According to such laws the response turns from brittle to almost fully plastic, as shown in Fig. 4.3

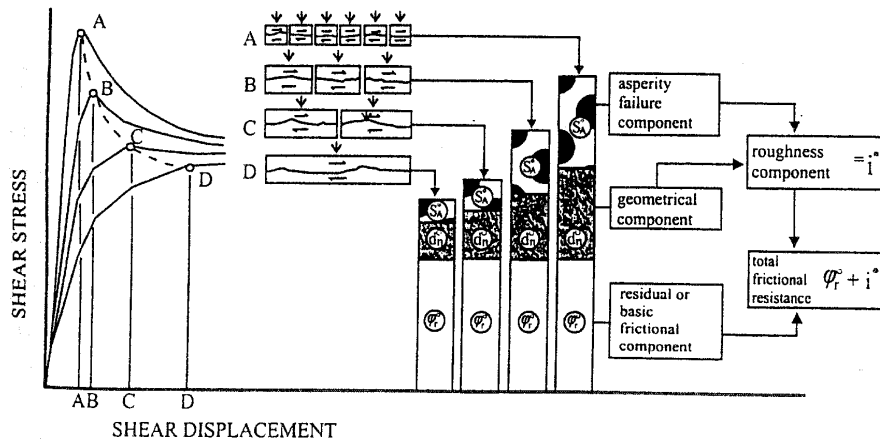

Fig. 4.3: Response to shearing of specimens of different size (from Ref. 4.3)

The peak shear stiffness and the displacement required to reach peak shear strength are (Fig. 4.4. and Fig. 4.5):

- $K_s = (100/L) \sigma_n \tan(JRC \log(JCS/\sigma_n) + \varphi_r)$
- $\delta = L_n/500 (JRC_n/L_n)^{0.33}$

The Coulomb representation is again a linear interpolation of the Barton curve within the confining stress range, which may be applied to both peak and residual conditions.

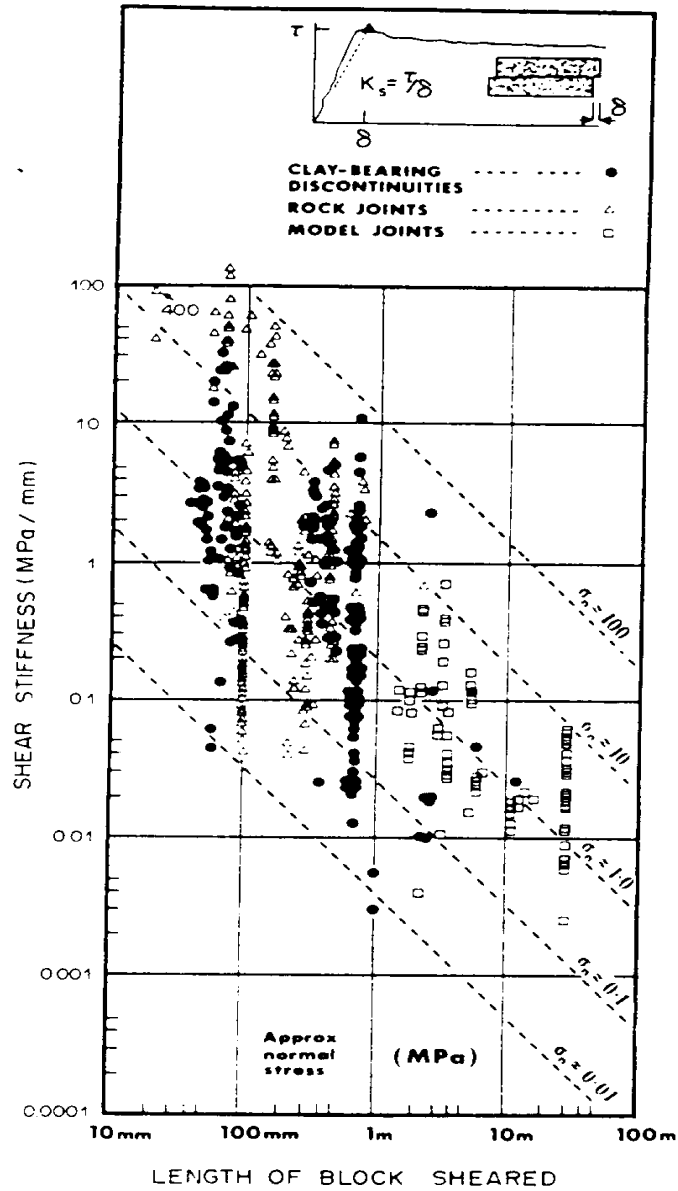

Fig. 4.4: Size effect on the shear stiffness in rock joints (from Ref. 4.2)

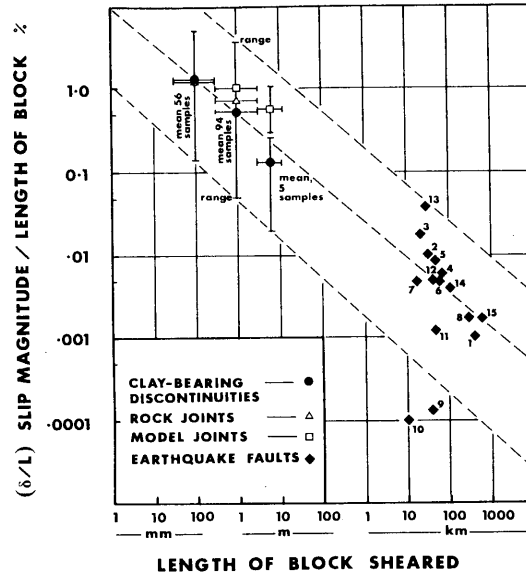

Fig. 4.5: Size effect on the slip magnitude in rock joints (from Ref. 4.2)

4.2 Deformable body approach

In the ‘deformable body’ approaches describing the dam and its foundation are described as deformable bodies.

Depending on material properties within the straining range of interest, the models may be linear and non-linear.

Typically, they incorporate the deformability of the materials and a sliding/opening criterion for the joints/discontinuities, which are the main source of non-linearity. Increasing loads may promote joint opening and penetration of uplift pressures.

They are well suited to incorporate many details of the actual loading sequence and of the geometrical layout, since finite element/boundary element models are used. Further, they allow for many refinements to the constitutive modelling.

Safety evaluations are managed through local checks of the available safety margins. Collapse mechanisms can be handled, typically by increasing loads to arrive at the evaluation of global safety margins expressed as load multiplying factors.

The straining range they can most reliably describe are those typically recovered by measurement data (dam monitoring), which are often used as validation tool. To reach the strain level associated to collapse mechanisms, dam displacements outside the range of the actual observations are

expected. Further, numerical difficulties need to be overcome to stretch the solution to the ultimate state.

When comparing their results with those given by global equilibrium methods, some standpoints concerning the loading conditions need to be ruled out, such as:

- the loading sequence: different sequences provide different safety margins in the non-linear domain;
- the loading rate, and the relevant consequences on the modelling of the uplift pressures.

The presence of substantial shearing at the tip of the joint/interface may favour the rotation of principal stresses in such a way that the crack path is prone to dip into the surrounding material. Within the latter perspective, also non-linear rock or concrete behaviour should be introduced. Under the most usual conditions the non-linearity in the concrete mass or within the rock mass appears not as significant, since the dam tends to unload in the vicinity of the opening joint, promoting its shearing.

The higher compression margins of bulk materials prevent from considering concrete crushing a priority event. Still this aspect should be screened under specific circumstances, where poor quality materials surround the joint/interface.

4.3 Constitutive behaviour and models

The constitutive behaviour of joints/interfaces is ruled by different parameters, depending on the modelling approach: tensile strength, cohesion and friction angle in elasto-plastic approaches, fracture toughness and fracture energy in linear elastic and non linear fracture mechanics models respectively.

The constitutive models usually adopted are of the Mohr-Coulomb type (par. 4.3.1). To better adhere to the actual response of joints, a criterion for joint opening can be added to that promoting shearing.

Data regarding the properties of joint interfaces can be retrieved from tensile and shear tests, on core specimens of the joint or *in situ*.

Based on the same experimental evidences, non-linear fracture mechanics (NLFM) models have been developed, which introduce a strength and an energetic criterion for the opening and the sliding of a joint/interface (par. 4.3.2)

Linear elastic fracture mechanics (LEFM) models represent structural instability conditions of an interface on a purely energetic basis and make use of a different set of experimental data (par. 4.3.2).

4.3.1 *Elasto-plastic approach*

This approach is often associated to the modelling of the joint/interface by means of contact/gap/interface elements.

As far as the normal stresses are concerned, a unilateral kinematical constraint is usually simulated, when the tensile strength is exceeded.

As far as the shear stresses are concerned, the constitutive model may be idealised as in Fig. 4.6.

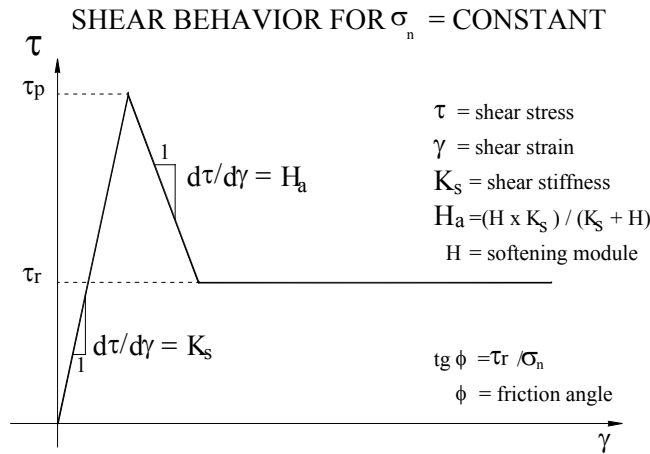

Fig. 4.6 : Idealised constitutive model (shear stresses)

The material behaviour is elastic until the peak strength is reached. At increasing strain the joint enters in the softening phase where damage is produced and the strength drop is ruled by a negative stiffness parameter (apparent softening module). In this phase the overall sliding has an elastic deformation component, γ_{el} , and a plastic one γ_{pl} ⁷. It is therefore assumed that the damage parameter is the cumulated irreversible deformation γ_{pl} .

⁷ The strength drop is the following incremental relation : $d\gamma = d\bar{\tau} H_a$ where H_a is a stiffness parameter (the apparent softening module)

$$d\gamma = d\gamma_{el} + d\gamma_{pl}$$

$$d\gamma_{el} = d\tau / K_s$$

$$d\gamma_{pl} = d\tau / H$$

In the above expressions H is the softening module. From the above relations, it is possible to derive: $H_a = (H \times K_s) / (K_s + H)$

In the softening phase the joint resistance decreases until the residual strength is reached. The following residual phase is characterised by an ideal elastic-plastic response. Shear straining is associated to displacement normal to the joint plane (dilatancy).

In Fig. 4.7 the peak and residual domains are linear, and depict the Mohr-Coulomb model. They are the bounding states (initial and final) for the decay of the shear resistance beyond the elastic domain. Both domains allow for different strengths at different confining stress. The residual domain is characterised by no cohesion (simplifying assumption used in many practical cases).

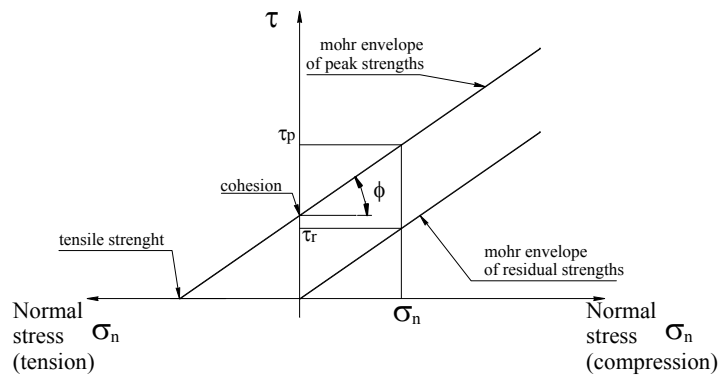

Fig. 4.7: Idealised strength domains in the σ_n - τ plane

4.3.2 Fracture mechanics applied to joints

To evaluate the formation and propagation of discontinuities, the criterion used to decide if irreversible deformations are taking place is generally based on stresses. At the interface tip an extremely high stress concentration predicted by a stress approach (for an elastic material infinite stress is predicted by theoretical solutions).

Linear/non linear fracture mechanics concepts are therefore used to establish more adequate stability criteria for interfaces.

- *Linear elastic fracture mechanics (LEFM)*

Evaluation criteria provided by LEFM are based on energetic parameters such as the tenacity.

Critical values of tenacity (or “toughness”) are determined by experiments.

The stress intensity factors K are determined and compared to material tenacity to evaluate crack stability. They can be interpreted as a measure of the velocity at which the stresses tend to infinite when approaching the

crack tip. When the stress intensity factor reaches the critical value (the tenacity), the crack is unstable and can propagate.

In a plane analysis, tenacity in Mode I (instability by opening) and Mode II (instability by sliding) must be known, together with appropriate tenacity domain to rule mixed mode.

For the concrete, the Mode I is usually thought as the prevalent mode.

Stress intensity factors are related to fracture energy and they can be expressed in closed-form relations within the linear elastic domain. Energy-based instability criteria can then be established as well, based on a scalar energetic parameters as the so-called J-integral.

The LEFM approach has proved valid when the crack length is limited respect to the available cracking path. Experiences on scale models of dam buttresses have proved that (Ref. 4.4).

▪ *Non linear fracture mechanics*

In fracture mechanics the deformation energy (G_f) is the energy released during the development of the cracking process, measured by the increase of the relative displacement occurring between the two crack lips.

The material property G_f relates strength to displacement.

In materials, such as concrete, where cracking is the result of a continuous deterioration process (damage), the deterioration mechanism may be resorted to strength criteria (e.g. the principal maximum stress reaches the tensile strength) and cracking to the release of the fracture energy.

This is the concept underlying the non-linear fracture mechanics approach.

To fully appreciate the physical meaning associated to the fracture energy as a material parameter in addition to strength, attention should be paid that no crack instability (and growth) is predicted until a zero stress carrying capacity is reached across the damaged zone. This occurs at a given limiting displacement. Before that stage damage, as micro cracking, is produced, depressing the available strength, still under a stable condition.

4.4 Numerical models

Finite elements, finite differences or boundary elements are employed for numerical analyses. The finite element is by far the most common method.

Based on the numerical approach we can distinguish:

- Discrete crack models. In these models cohesive forces are present in the process zone (zone close to crack tip where the non linear effects

are concentrated). Cracks are modelled by disconnecting adjacent nodes or setting in the numerical model special ‘interface’ elements. Crack paths are produced by disconnecting further nodes. The procedure may require sub-structuring and re-meshing capabilities to the code. In general, *ad hoc* codes are developed for this scope. Boundary element techniques have been developed to make this approach computationally more attractive.

- Smearred crack models, where a cracked solid is anyway assumed to respond as a continuum. The behaviour of a cracked solid is then described in terms of stress-strain relations and it is sufficient, at cracking, to switch from the initial isotropic material to an orthotropic one. So the topology of the finite element mesh is preserved, and this is computationally convenient.

The latter approach is quite popular since it allows including in the same analysis all the stages of the response. The fracture path and crack aperture can be predicted without resorting to the physical detachment of the crack. It brings in a mesh size dependency factor into the numerical solution.

Special finite elements (‘quarter point’ elements) have been developed to capture the elastic solution at the crack tip. The ‘quarter point’ elements are generally used in linear elastic fracture mechanics. In Fig. 4.8 the level of meshing typically used in this approach is shown.

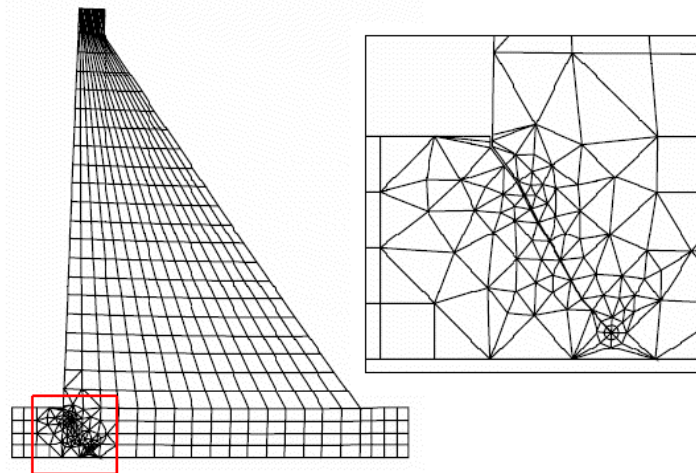

Fig. 4.8 - Linear elastic fracture mechanics -Typical level of meshing

Continuum elements with embedded discontinuities, able to capture the discontinuous kinematics characterising the interface opening have been recently developed. They, essentially, supplement the standard finite

elements with additional internal degrees of freedom whose associated shape functions are discontinuous inside the element.

4.5 Coupled response

Joints and interfaces may not only affect the mechanical behaviour of the dam and foundation, but also their diffusion properties (flow of water, moisture, etc).

Joints and interfaces may therefore be the source of coupled phenomena.

Water penetrates throughout a crack with a velocity ruled by the crack permeability. The latter is a function of joint opening, typically by cubic laws (for further details, see Ref. 4.5).

In fracture mechanics models water pressures are introduced as forces applied to the sides of the joint. Value and distribution of such forces at each step of the analysis should be governed by an *ad hoc* model (water pressure vs. joint opening), and the capability of updating such pressure distribution should be available.

The Biot coupled formulation associated to crack models allows predicting water pressure as one of the variables of the differential solution. The modelling of the crack growth and the development of the associated water penetration and pore pressure growth are specific aspects of these models, taking into account the full coupling of stress and hydraulic response.

The fracture path is one of the results of the solution algorithm, hence there is no need to assume predefined paths.

The crack propagation speed depends on the solid skeleton mechanical behaviour, on the speed of application of the external load and fluid transport time scale. Hence it is hence one of the results of the analysis, as the evolution of the stress and pressure fields.

The fully coupled approach is a theoretical framework broadening the support capabilities of mathematical modelling. There are, on the other side, more demanding theoretical/numerical formulations, and gaps which need to be settled.

Remarks on this approach have been proposed in the Report issued by the ICOLD European Working Group on Uplift Pressures (Ref 4.5).

4.6 Size effects on material parameters

The main concerns connected to the use of actual experimental values (*in situ*, in laboratory) can be synthesised as follows:

- How far results can be extrapolated to the entire joints surface;
- How far the shear and frictional properties are affected by the small dimensions of specimens retrieved from coring.

The so called size effects have different sources:

- The issue of Representative Elementary Volume on experimental results. This volume is the minimum, which can represent the overall volume. It is a consequence of the material's microstructure non-homogeneity. As an example, it is well known that concrete specimen should be large enough as to include 3 times the maximum aggregate dimension. In joint testing such dimension, which mainly depends on geometrical interface properties, is sometimes attained in some in situ tests or in large dimension testing in laboratory. The most common test results refer however to much smaller specimens.

Parameters obtained with the latter need careful consideration. To derive adequate values from few tests on small-scale specimens entails mature engineering judgement.

A quite comprehensive formal treatment of this aspect is given in rock mechanics literature, and is formally exploited in the shear strength model of Barton (see paragraph 4.1.2).

Size effects affect as well parameters ruling the non-linear fracture mechanics approach (strength and fracture energy). Stiffness parameters are affected as well. In LEFM toughness coefficients are retrieved from tests on pre-notched structures. A vast literature is available about size effects related to such experiments. An ad hoc test (the wedge splitting test) is being used to retrieve fracture mechanics parameters for dam concrete. In dam engineering the wedge-splitting tests has been given wide recognition in recent years.

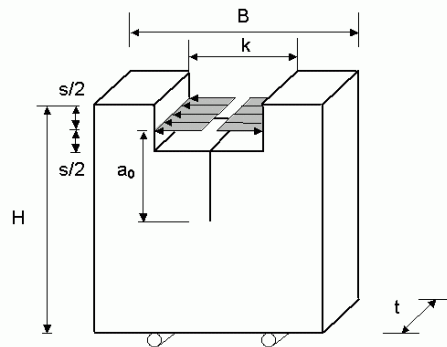

The wedge splitting test concept

- Size effects embedded in the numerical solution. Adequate refinement of the space and time domain is a key-point for an effective numerical solution and accurate results.

Important stress concentration in the area surrounding the joint/crack tip need careful local refinements of the mesh.

In non-linear smeared crack models the constitutive laws, which link strength to displacement, needs to be processed. Typically a dimension is established, the so-called ‘crack band’, which allows establishing strain from displacement. How to determine the crack band, how far it is related to the Representative Volume, are issues widely investigated in concrete mechanics.

In a coupled model the mesh layout must be established taking into consideration also the pore pressure gradients, which not always are located where stresses concentrate.

4.7 Modelling experiences

A selection of experiences available in the technical literature on the impact of discontinuity modelling on dam safety assessments is briefly commented in this chapter.

4.7.1 Elastic-plastic solution

Ref. 4.6 reports about sensitivity analyses carried out to evaluate the influence of:

- different approaches for the calibration of the constitutive model for the dam-foundation interface;
- different uplift pressures distributions;
- Different sloping values of the dam-foundation surface and lift joints.

The first factor was examined by finite element analyses; the others by a conventional limit equilibrium method.

The sensitivity to model parameters resulted less than the sensitivity to variation of the uplift pressures. Safety factors moved from unsafe values, when adopting standard distribution for uplift pressures, to safe values, when actually measured uplift pressures were used.

4.7.2 Non Linear Fracture Mechanics solutions

In the comprehensive research programme reported in Ref 4.3 a review of the methods for the safety assessment of concrete dams, with specific reference to the influence of lift joints, was carried out. Furthermore, an ad hoc thin layer interface finite element was developed.

Three case studies were studied, using such thin layer interface finite element to model the lift joints and the dam-foundation interface. Safety conditions were studied progressively increasing the reservoir level.

- In Case n. 1 a masonry dam, 41m high, was examined. A weak and a strong hydro mechanical coupling were analyzed, to address uplift pressure development within interfaces. The results demonstrated that the use of a weak or strong coupled approach depends on the relative permeability of the interface respect to that of the surrounding material. The weak approach (introduction of full water head in the opened crack) is suited when the permeability of the crack/joint is much higher than that of the surrounding material. The strong coupling, requiring a seepage analysis at each step, is better suited when these permeabilities are comparable.
- In Case n. 2 a concrete gravity dam, 18m high, was examined. Both the dam-foundation interface and the lifts joints were modelled, and several different approaches were applied: Limit equilibrium method (cracked base); crack propagation based on principal stresses, without joints; Mode I crack propagation based on normal stresses only, with joints; Mixed Mode crack propagation ((I and II, normal and shear stresses), with joints. The critical water level for sliding, resulting from the different analyses, spanned over 1m (5% about, see Fig. 4.9).

Table 4.3: Critical water level for sliding computed from different types of analyses with water-fracture interaction ($f_t=5$ kPa, $G_f=10$ N/m for FE analyses only).

Type of Analysis (with pressure updates)	$\phi = 37^\circ$ $c = 0$ $\phi_{res} = 37^\circ$	$\phi = 45^\circ$ $c = 0$ $\phi_{res} = 45^\circ$	$\phi = 55^\circ$ $c = 0$ $\phi_{res} = 55^\circ$	$\phi = 55^\circ$ $c = 0$ $\phi_{res} = 45^\circ$	$\phi = 55^\circ$ $c = 329.2$ kPa $\phi_{res} = 45^\circ$
Gravity Method Cracked base Analysis	17.1 m (0%)	18.1 m (U23%)	18.5 m (U54%)	N.A.	18.8 m (U87%)
FE Method (without joint): Principal stress Analysis	16.2 m (U55%)	17.3 m (U65%)	17.7 m (U100%)	17.7 m (U100%)	17.7 m (U100%)
FE Method (with joint): Normal stress Analysis	17.3 m (U5%)	18.3 m (U35%)	18.8 m (U60%)	19.0 m (U80%)	19.0 m (U80%)
FE Method (with joint): Normal stress Analysis combined with local shear-compression	16.5 m (U45%, D20%)	16.8 m (U15%)	17.3 m (U40%)	17.3 m (U40%)	18.7 m (U70%)

U, D : length of opened crack, from upstream (U) or downstream (D))

Fig. 4.9: Some results for case n. 2 (from Ref. 4.3)

From the results of Case 2 the Authors conclude, among other, that:

- The strength of the dam-foundation interface controlled the structural stability, without sliding or cracking along lift joints.
- The consideration of a local shear-compression failure criterion (mixed mode) significantly influenced the crack propagation and predicted critical load.
- The solution resulted much more sensitive to the peak friction angle than to the residual one, for the dominant overturning contribution to the overall failure mechanism.

- In Case n. 3 a gravity dam, 116m high, made of very poor concrete, was examined. A non linear crack model was introduced in the concrete mass, together with appropriate modelling of the joints. This example outlined a strong influence of the behaviour of the overall dam (not only of joints) on the resulting crack pattern and safety margins. Failure mechanism was characterised by cracks propagating along several lift joints, jumping from one joint to the adjacent one. The possibility of diagonal cracks propagating from horizontal is suggested as a possible failure mechanism (see Fig. 4.10, in which the propagation of a “damage index” is shown).

It must be underlined that these results are clearly influenced by the poor and uneven mechanical properties assigned to the concrete (6MPa compressive strength for the dam body).

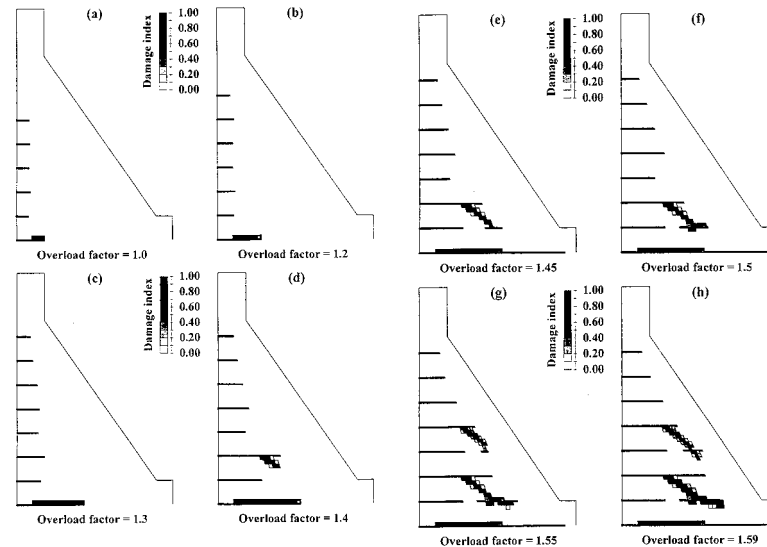

Fig. 4.10: Propagation of damage (from Ref. 4.3)

4.7.3 LEFM solutions

Linsbauer [Ref. 4.7] presented solutions for the safety evaluation for a dam buttress, by linear elastic fracture mechanics techniques (Fig. 4.11).

A chart for the safety assessment of an idealised dam profile has been developed, to assess the conditions favouring instability of the dam-rock foundation interface under the assumption that the weak interface lays within the dam body. The normalised stress intensity factors K_I and K_{II} plots are given under different ratios of stiffness E_D/E_R of the dam respect to rock.

Another interesting case is proposed by Saouma et Ayari in Ref. 4.7 where fracture mechanics approaches under isotropic/anisotropic conditions, both in static and dynamic conditions, are presented.

Authors discussed LEFM solutions respect to limit equilibrium methods, referring to the Upper Stillwater dam (Utah) and outlining that, at a given dam height, the latter are much more conservative and more sensitive to the material parameter change than the former

4.7.4 The 5th International Benchmark Workshop

The 5th International Workshop on Numerical Analysis of Dams (Ref 4.8), organised by the Numerical ICOLD Committee, addressed the evaluation of the critical reservoir level associated to the 'imminent failure' of a concrete gravity dam.

The 'imminent failure' condition had to be reached by increasing the hydrostatic load, up to the ultimate water level I.I.F (Imminent Failure Flood).

In the proposed assessment the main issue was a realistic representation of the sliding conditions of the rock/concrete interface.

The problem was idealised to a degree comparable to that commonly required by Regulations or standards, except for the representation of the stress-strain response of the base joint (dam-foundation interface).

The latter was described as a piecewise-linear idealisation of the experimental response, with a sharp peak at low tangential straining, followed by a softening branch and a final (residual) straining at constant tangential stress (fig. 4.12).

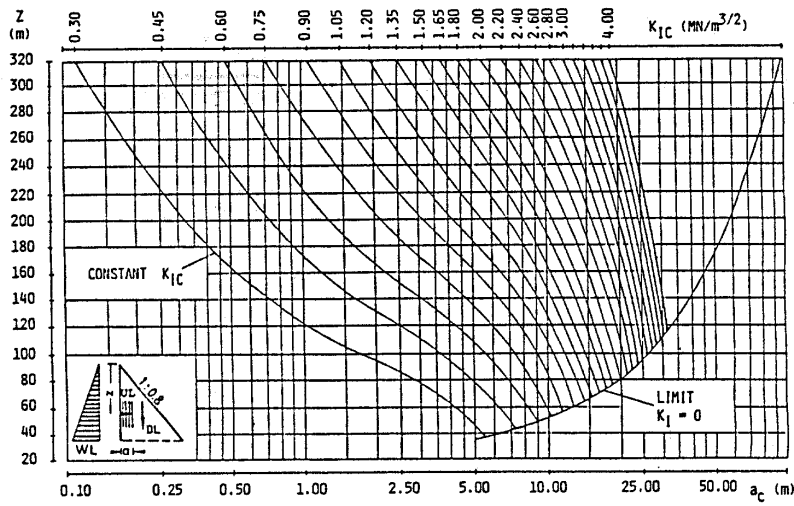

Fig. 3 Critical crack lengths a_c versus depth of crack level z and fracture toughness K_{IC} for a triangular dam profile (Levy) subjected to reservoir load, dead load and uplift pressure ($\lambda = 1.0$)

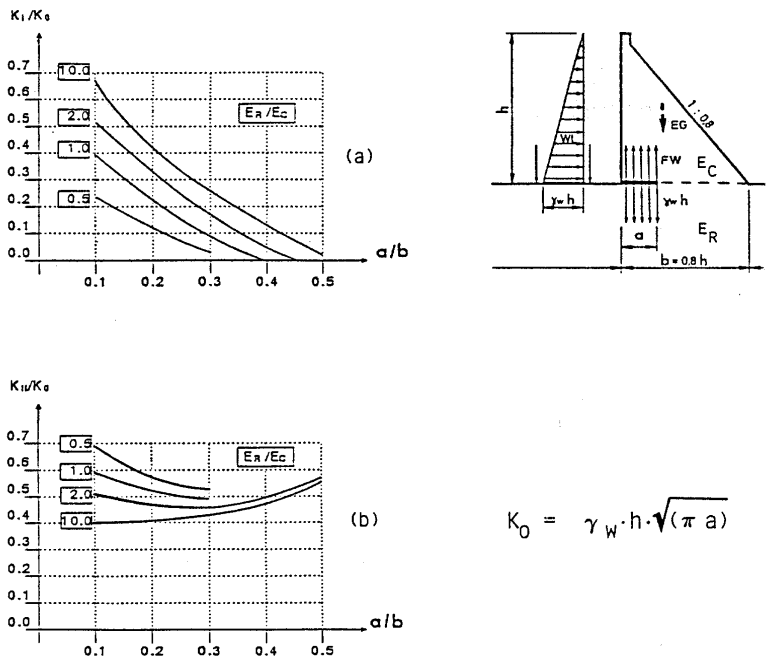

Fig. 4.11: Charts to derive stability checks for base and lift joints. LEFM approach – Source: Linsbauer

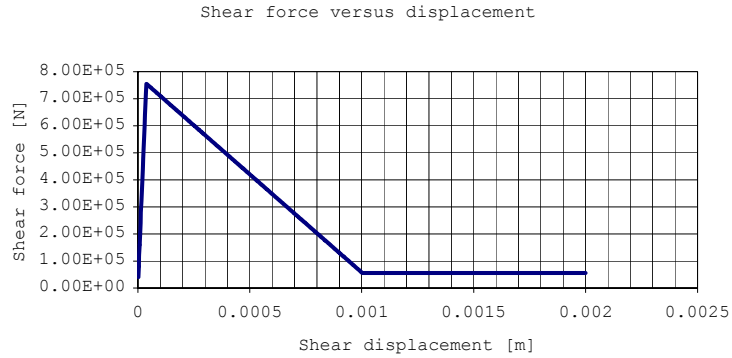

Fig. 4.12: Shear strength softening (from Ref. 4.8)

The solution method therefore falls within non-linear fracture mechanics deformable body methods. Mesh size independency needs to be obtained by selecting an appropriate crack band width.

Three situations were proposed for the uplift pressures: none (Case 1), 100% drain efficiency (Case 2) and zero drain efficiency (Case 3), as shown in the sketches reported in Fig. 4.13.

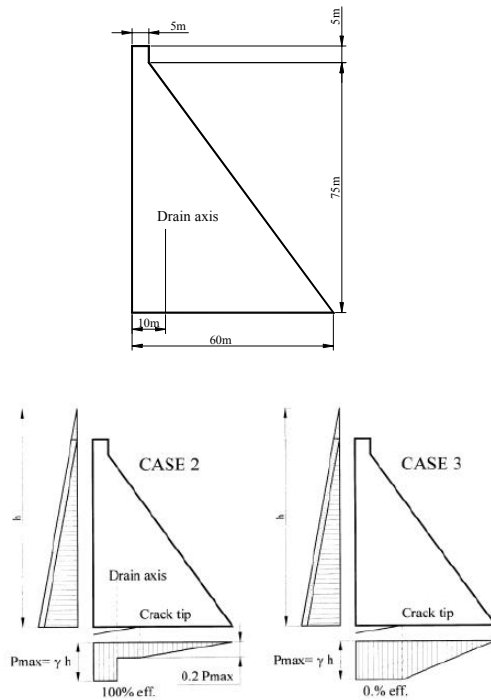

Fig. 4. 13 (from Ref. 4.8)

Some information and comments are hereunder given about some results given by Authors participating to the Benchmark.

The evaluated impending collapse conditions were sometimes remarkably different. As an example, the impending collapse condition evaluated by Palumbo et al. (Fig. 4.14) is clearly dominated by the joint opening, rather than shearing. The deformation of the dam at impending failure evaluated by Linsbauer and Battacharjee (Fig. 4.15) is clearly dominated by sliding along the interface.

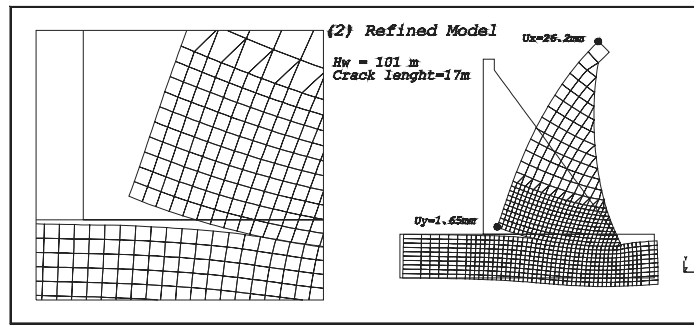

Fig. 4.14: Palumbo et al. (Ref. 4.8)

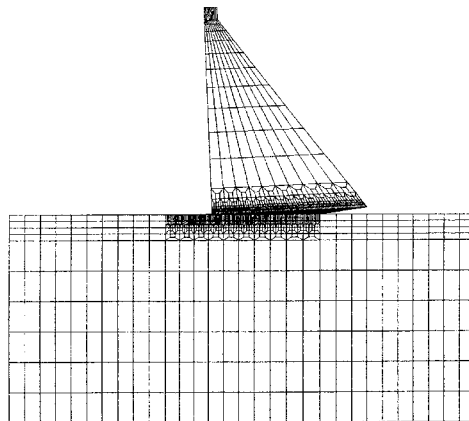

Fig. 5 Deformation of the dam for Case 3 (failure level)

Fig. 4.15 Linsbauer and Battacharjee (Ref. 4.8):

In the contribution given by Manfredini et al., in which the given problem was solved by both LFEM and NLFM methods and several different assumptions on the constitutive model of the dam-foundation interface, remarkable differences were pointed out between NLFM and LEFM

solutions resulting in different crack lengths and stress distributions along the interface. Also the material parameters showed a strong impact on the results.

Overall, examining the solutions calculated by all the participants to the Benchmark Workshop, the following remarks can be made:

- To incrementally arrive at the limit state – full sliding of the dam base - is numerically committing. Many numerical difficulties were encountered, due to the impact on the solution algorithms of the brittle constitutive behaviour of the joint.
- Results are significantly dependent on meshing strategy, such as the type of finite elements, and mesh refinement.
- The “water level – crown displacement” curve does not always display the attainment of limit conditions.
- The application and updating of uplift pressures to follow joint opening are specific features not available in standard finite element codes. Ad hoc procedures were used by the participants.
- The loading sequence was not specified as input data. Different adopted sequences contributed to the scattering of the solutions.
- According to the results obtained with various methods incorporating the full peak and residual response, the ultimate capability of resisting sliding resulted commanded by the peak conditions, rather than by the residual ones.
- Different scenarios on uplift had a strong influence on the final results.
- The results indicate that several computational and theoretical aspects need to be clarified, to confidently arrive at a robust solution.

4.7.6 *The solutions of the network IALAD*

The computational problem proposed in the 5th Benchmark Workshop, has been later on examined within the running *IALAD Network* Project, and the Cardiff School of Engineering issued a draft report comparing solutions (Ref. 4.9).

Overall discrepancies in the critical water level IFF, interface opening, collapse mechanisms have been found similar to those of the 5th Benchmark Workshop.

Overall issues identified by the Reviewer are the following:

- The used interface models were quite different and this resulted in some cases in markedly different solutions.

- Difficulties in achieving converged solutions were found when non-linear behaviour is activated.
- Manually adjusting the uplift forces at the interface as the crack tip moves is time consuming and prone to inaccuracy.

4.8 Conclusive Remarks

A substantial development of techniques resting on the explicit modelling of dam response to loads from the operational stage to the ultimate conditions, modelling the actual properties of the materials and interfaces, is available in the technical literature.

Many authors outline how useful is the capability of such methods to 'predict' the actual path of discontinuities/fractures and evidence that the most probable path of a weak interface may be more complex than foreseen in standard limit equilibrium analysis.

Linear fracture mechanics approaches are, in principle, not comparable with approaches representing interface damage by micro cracking before opening and sliding. For the same reasons, a link between the constitutive property of LEFM approaches, the fracture toughness (or fracture energy), and strength /fracture energy of non linear approaches may be only empirically estimated.

Methods relying on strength based criteria, irrespective whether they are fully elastic-plastic or non-linear fracture mechanics based, can be compared with rigid body solutions, only at a stage of the load-displacement response of the structure that needs to be determined. Such stage has been established in some cases on the water level-crown displacement curve. Its determination seems not always straightforward. In fact:

- At a significant damage stage the numerical solutions suffer of the increasing commitment.
- The numerical solutions depend on the assumed constitutive model for the interface: some are curvilinear, and associated to failure mechanisms where overturning gives a major contribution; other quasi-linear associated to a much sliding prone mechanism.

Departing from linear modelling, issues of model validation and justification need to be addressed, as:

- The definition of an agreed, well established sequence of loading
- The identification of the loading scenario in terms of load increase rates
- The selection of indicators to identify the achievement of ultimate conditions

The deformable body approaches is fully exploited only if a higher detail in the description of model properties is available respect to the design situation (“as built” condition, actual physical and mechanical properties of the materials, etc.). Depending on the amount and reliability of the available information, these approaches may allow to release some conservatism that is embedded in the limit equilibrium approach.

When applied to idealized verification schemes, i.e. departing from realistic conditions, it is still a question how far the abilities of such methods have a distinctive merit respect to conventional solutions.

4.9 Bibliographic References

- [4.1] N. Barton, S. Bandis, K. Bakhtar, *Strength, Deformation and Conductivity Coupling of Rock Joints*, Int. J. Rock Mech. Min. Sci. & Geomech. Abstr. Vol. 22, No. 3, pp121-140. Great Britain, (1985)
- [4.2] N. Barton, V. Choubey. *The shear strength of rock joints in theory and practice. Rock Mechanics*, 10,1-54, (1977)
- [4.3] Tinawi R., Lèger P., Ghrib F., Bhattacharjee S., Leclerc M., *Structural safety of existing concrete dams:influence of construction joints* , Contract CEA No., 9032 G 905, (1998)
- [4.4] Pellegrini R., *Effetti degli stati fessurativi sul comportamento strutturale osservato e calcolato delle dighe in calcestruzzo*, Accademia Nazionale dei Lincei, Convegno sui problemi strutturali nell’ingegneria delle dighe, (2004).
- [4.5] ICOLD European Working Group, “*Uplift Pressures Under Concrete Dams - Final Report*”, Proceedings of the ICOLD European Symposium “*Dams in a European Context*”, Geiranger (Norway), (2001).
- [4.6] D’Andrea L, Imperato L.(1997) Valutazione e previsioni delle proprietà delle discontinuità strutturali in opere di sbarramento in calcestruzzo. ISMES internal Report RAT-STR-2658/97, (1997).
- [4.7] *Scale Effects in Rock Masses* Pinto da Cunha Ed., A.A. BALKEMA (1990)
- [4.8] USCOLD *Proceedings Fifth Benchmark Workshop on Numerical Analysis of Dams*, Denver (CO), (1999)
- [4.9] Cardiff School of Engineering, *Integrity assessment of large dams, NW-IALAD. Task 2.4, Preliminary report on comparison of codes using various benchmark problems*. Draft. (2003).
- [4.10] Electric Power Research Institute *Stability Analysis of Concrete Gravity Dams*, Report No.EPRI TR-100345, Palo Alto California.
- [4.11] P. Lèger, R. Tinawi, S.S. Bhattacharjee, M.Leclerc, *Failure mechanisms of gravity dams subjected to hydrostatic overload: influence of weak lift joints* (1997)

- [4.12] U.S. Bureau of Reclamation, *Design Criteria for concrete arch and gravity dams*, United States of the Interior, Mon. N. 19. (1977)
- [4.13] H. Reinhardt, *Joints, Fracture Mechanics of Concrete Structures From theory to applications*. RILEM. Edited by L. Elfgren, published by Chapman and Hall, London, (1989)
- [4.28] Bettzieche V. and Heitefuss C., *Monitoring as a basis of cost – effective rehabilitation of an old masonry dam*, ICOLD European Symposium Norway, Geiranger (2001).

5. THREE-DIMENSIONAL EFFECTS

5.1 General remarks

Three dimensional effects might have a significant influence on the predicted ultimate load and failure mechanisms of a gravity dam.. Therefore, a negative conclusion from a 2D analysis of a single monolith is subject to caution if 3D load sharing mechanisms can be mobilised across adjacent monoliths.

The possibility of 3D effects is more evident for gravity dams with arched axis, but 3D effects may be present also in dams with straight axis.

The behaviour of the vertical construction joints is the main factor influencing the possibility that 3D effects are activated by the structure. Their design and construction details play an important role on this matter (joint shape, keyed or un-keyed joints, joint treatment, construction opening, joint grouting).

Other factors may influence the actual behaviour of the joints: deformation induced by the operational loads (thermal seasonal deformations, twisting of adjacent monoliths), creep effects, swelling phenomena, etc.

Swelling phenomena in concrete are becoming not unusual, in particular in old dams. Slow expansive behaviour can induce in course of time suitable conditions for 3D effects.

Shear friction resistance at the joints, related to compressive forces that may develop perpendicular to the joints, can contribute to the development of 3D effects even through un-keyed joints. It must also be noted that there are gravity dams designed and constructed without vertical joints.

The 3D effects are usually neglected in the design of new dams, but they should not be neglected in the safety reassessment of existing dams, when they may play an effective role. The Canadian Dam Safety Association Guidelines explicitly point out to take them into account (see Chapter 1).

The 3D effects may be particularly important when the results of the sliding safety assessment are conditioned by specific defective horizontal joints, inasmuch as defective lift joints are unlikely to be continuous across several monoliths.

5.2 Information from the actual dam behaviour

Information about possible 3D effects should be derived from the actual dam behaviour. In addition to the evaluation of the measurement data (dam monitoring), specific investigation and tests can be carried out to increase the available knowledge.

The amount of the available knowledge is crucial to take into account 3D effects in structural analyses and safety assessment, and to overcome the numerous uncertainties and difficulties to be faced in a 3D analysis.

Valuable information about 3D effects can be derived from the monitored dam displacements, being the deformability of the dam as a 3D body remarkably smaller than that of a 2D cantilever. The measured displacements must be examined to identify the thermal and the hydrostatic components, which should be compared with corresponding theoretical values computed for 2D and 3D behaviour.

Useful information is also given by the monitoring of the behaviour of the vertical joints. This monitoring is usually carried out by means of extensometers installed across the joint (usually at the crest, sometimes along the downstream face, very seldom along the downstream face). The monitoring data are often limited to the joint opening only, and provides information only about joint opening variations (not about joint construction gap). In spite of these limitations, the joint monitoring can contribute to the recognition of 3D effects in the dam behaviour, in particular to detect slow and progressive variations in course of time as those due to swelling phenomena in the concrete. When swelling phenomena are involved, also the data given by vibrating wire strain gauges embedded in the concrete mass may be helpful.

Among the in situ investigations, an effective way to detect 3D effects is the investigation of the dynamic fundamental frequencies and mode shapes of the dam. This can be done, for example, by means of in-situ forced vibration tests.

This type of investigation has been carried out on several Italian gravity dams with arched axis, and a clear 3D dynamic behaviour - 3D mode shapes and corresponding fundamental frequencies – resulted from the tests (see, as an example, Fig. 5.1).

As for the static behaviour, a theoretical reference model is a valuable tool for the best interpretation of the measured dynamic behaviour.

Even when a lot of information can be derived from the actual dam behaviour, uncertainties will unavoidably remain. Thus, sensitivity analyses to evaluate the influence on the results of the most uncertain and governing parameters are a clear need.

5.3 Structural analyses - Gravity dams with curved axis

The most evident 3D effect is the development of an arch strength mechanism in gravity dams with arched axis

The arching of the dam axis is a design solution adopted in a not negligible number of gravity dams. In many cases it corresponds to the clear intent of the designer to provide the gravity dam with additional strength resources against sliding..

Of course, adequate morphological and geo-mechanical characteristics of the foundation are required, so that the foundation (in particular the abutments) can withstand the forces transmitted through the arch strength mechanism.

Furthermore, the vertical joints must be radial, and their opening must be small enough, to enable the structure to develop the arch mechanism without too large deformations which may be not acceptable for the dam integrity.

When 3D arch effects are activated, the strength resources may be much larger than those of the “independent gravity monolith”.

Consequently, 3D analyses are called for, to take into account these additional resources, but several uncertainties and difficulties must be faced in 3D analyses. The structural behaviour of the dam subjected to increasing loads may progressively change during the loading path, depending on the type of load, the loading combination, the loading path, the level of stress and deformation and the related material behaviour, the modification of the interaction forces through the vertical joints, etc.. This involves a progressive evolution of the structural response scheme, from a complete or prevailing 2D scheme – for low load levels – to a complete or prevailing 3D scheme for high load and deformation levels.

This may be noted in Fig. 5.2, obtained from experimental loading tests on a physical model (scale ~ 1: 100) of an arched gravity dams with keyed vertical joints (source: ISMES). The figure illustrates the measured displacements of the dam toe vs. the amplification factor (N) of the design load. The curves put in evidence the modification of the response mechanism during the tests, at increasing N.

So, an effective 3D analysis is a demanding task, requiring skilled structural and modelling experience, joined to mature engineering judgement.

5.3.1 *Limit equilibrium approach*

The use of a limit equilibrium approach for the evaluation of the bearing capacity taking into account the arch mechanism is presented in Ref. 5.1.

The approach is the extension to the 3D field of the 2D simple assessment criterion based on the ratio between the vertical (N) and the horizontal (T) components of the external forces acting on the sliding surface.

The extension of this criterion to a 3D condition is based, at first, on the evaluation of the sliding safety of the whole dam body, assuming that elastic and unilateral restraint is exerted by the foundation (i.e. only compressive reaction forces) and that the ratio ('f') between the tangential and perpendicular reaction forces is uniform along the whole dam-foundation interface.

By means of the six "rigid body" equilibrium equations, the reaction forces along the dam-foundation surface are evaluated through an iterative solution process. They depend of course on the assumed 'f' value.

The acceptability of the obtained solution is evaluated comparing the assumed 'f' value and the reaction compressive stresses along the dam-foundation interface with the allowable strength parameters.

Once the equilibrium of the whole dam is assessed, the equilibrium of parts of the dam (groups of blocks, single blocks, parts of a single block) is examined, following the same procedure.

The application of this approach to several arched gravity dams pointed out very remarkable resisting resources due to the arch effect. In all the examined cases the conventional 2D approach resulted in T/N ratios larger than the allowable value not enabling positive conclusions about dam safety, while largely positive conclusions were derived from the 3D approach.

5.3.2 *The 7th ICOLD Benchmark Workshop*

A theme of the 7th Benchmark Workshop, promoted by the ICOLD "ad hoc" Committee on Computational Aspects and held in 2003 in Bucharest, has been devoted to the numerical analysis of a gravity dam with a curved axis.

The exercise proposed to the participants asked for the evaluation of the ultimate strength against sliding taking into account the curved shape of the dam. In Figure 5.3 the dam selected for the exercise (Scalere dam, Italy) and the finite element mesh proposed to the participants are shown.

In order to reduce the uncertainties and make the results more comparable it was requested to evaluate the ultimate strength against sliding in terms of the maximum hydrostatic level, expressed by a multiplier of the given design water level. In addition, participants were also asked to provide the

normal and shear stresses on the dam-rock interface, on the main cross vertical section, and on a horizontal arch.

Six papers were presented. All the participants used finite element models, resorting to commercial or own-developed codes.

Different material models were used for concrete and rock (linear elastic; non-linear, with different constitutive laws). Different joint models were used for the dam-rock interface, and the uplift pressures were assumed accordingly. As failure criteria, participants considered both physical-mechanical aspects (full mobilization of shear strength, large displacement at the dam-rock interface, etc.), as well as the numerical non-convergence of the analyses.

Among the interesting remarks derived from the results of the Benchmark, it is worthwhile to mention the following: in spite of the different adopted material models and failure criteria, the water level amplifier corresponding to a “generalized sliding” (ultimate strength), ranged in the rather narrow band 1.18-1.33, as resumed in Fig. 5.3 (from Ref. 5.2).

Some participants put into evidence that the failure mechanism starts at the banks, others emphasized the important role of cohesion value in the attainment of the limit equilibrium condition, others commented about the evolution of the dam behaviour from a gravity resisting mechanism to an arch resisting mechanism at increasing reservoir level.

5.4 Structural analysis - Straight axis gravity dams

Three dimensional load carrying mechanisms could develop also in gravity dams with straight axis, in narrow valleys.

When adjacent joints have rapidly changing heights, due to slope of the canyon, if the vertical contraction joints are interacting, the movements of the higher more flexible cantilevers may be restrained by the adjacent shorter and stiffer ones, and the applied loads may be redistributed between the monoliths and possibly a fraction of the thrust may be carried to the canyon walls.

For instance, this type of behaviour was pointed at Schräh dam (Ref. 5.3).

The difference between a 2D and a 3D behaviour, in terms of stresses and stability factors, is since a long time investigated.

Parametric studies were carried out in early seventies by Campbell-Zienkiewicz (Ref. 5.4), investigating the stress redistribution produced by a 3D behaviour. For narrow valleys the stresses calculated by a 3D model resulted significantly reduced, as compared to those computed by a 2D analysis (Fig. 5.4). Of course, these results have a mainly qualitative

meaning, deriving from linear elastic analysis not considering any non linear effect.

The 3D effects have been investigated not only by Finite Element models. The concept of “hidden arches” through the blocks of straight gravity dams in narrow valleys was pointed out by Herzog (Ref. 5.5, Fig. 5.5), and it was accounted for by a “grid analysis” (similar to that used in the Trial Load Method), idealising the dam as a grid of vertical cantilevers and horizontal beams. To take into account the construction joints the horizontal beams were assumed tension-free, carrying the water load by arch action. The use of this approach for the Grand Dixence dam showed that the deflection at the crest and the bending moment at the base of the central cantilever were reduced by the grid action of about 30%, compared to a 2D central cantilever analysis (see Fig. 5.6).

However, Hohberg (Ref. 5.6) put in evidence that this computational approach completely disregards possible slacks in the construction joints, that the arch-mechanism is likely to be activated after a first failure as a 2D dam (cantilever and arch resistance mechanisms are thus not additive), and that the mechanisms that transfer loads to the valley flanks differ from the “tension-free beam” scheme.

The continuous interest always given to the subject is demonstrated for instance by the comparative parametric studies recently reported in Ref. 5.7, in which 3D effects and their influence on the safety factors against sliding were investigated by means of linear and non linear FE analyses (Fig. 5.7).

The analyses carried out for Soha dam (Ref. 5.8) offer an interesting example of 3D effects taken into account in the sliding safety re-assessment of a straight gravity dam not meeting usual 2D safety criteria.

Soha dam is a rather small dam (height: 31 m, crest length: 132 m), built in a narrow valley with steep abutments. The dam monoliths are interconnected with grouted concrete keys, preventing differential deflection between adjacent monoliths.

Traditional 2D analyses showed that the dam did not meet acceptable stability criteria and required stabilisation works. Additional analyses were carried out to take into account the 3D behaviour. A “cracked base” approach was applied, by reducing the elastic modulus of selected elements along the contact and increasing the uplift pressures at this location.

The results showed a significant reduction of the crest deflection (Fig. 5.8), and stresses compatible with the required safety criteria.

The evaluation of the sliding stability factors was based on the shear and normal forces at the base of each dam block, derived from the Finite Elements analysis. The results indicated that the interaction between the

monoliths allowed the less stable ones to gain stability from the more stable ones, and that the required stability criteria could be without rehabilitation works.

5.5 Bibliographic References

- [5.1] Fanelli, M., Mazzà, G., Ruggeri, G., Palumbo, P., 1995, "Gravity dams: safety evaluation again sliding with a 3D rigid body formulation" , Meeting on research and Development in the Field of Dams, Crans Montana (Switzerland), pp. 253-264
- [5.2] G. Mazzà, "Evaluation Of Ultimate Strength Of Gravity Dams With Curved Shape Against Sliding : Synthesys of Results", 7th Benchmark Workshop on Numerical Analysis of Dams, Bucharest, September 24-26, 2003
- [5.3] Swiss National Committee on Large Dams, "Swiss dams- Monitoring and Maintenance", Edition for the 15th ICOLD Congress, Lausanne 1985
- [5.4] Campbell, J.S., Zienkiewicz , O.C., 1975, "Gravity dam analysis – The effect of valley width", Int. Symposium on Criteria and Assumptions in the Numerical Analyses of Dams, Swansea.
- [5.5] Herzog, M.A.M., 1989, "Spatial action of straight gravity dams in narrow valleys", ASCE Journal of Structural Engineering - Vol. 115, n.3, pp. 698-706 - Vol. 117, n.2, pp. 640-641.
- [5.6] Hohberg, J.M., 1991, „Discussion of spatial action of straight gravity dams in narrow valleys”, ASCE Journal of Structural Engineering - Vol. 117, n.2, pp. 637-640.
- [5.7] Brunet, C., Divoux, P., 2002, "Study of 3D behaviour for the evaluation of the stability of concrete gravity dams", Int. Congress on Conservation and rehabilitation of Dams, Madrid (Spain), pp. 885-890.
- [5.8] Lund, S.G., Boggs, H.L., 1994, "Soda dam: three-dimensional analysis of a concrete gravity dams", ICOLD 18th Congress, Durban (South Africa), Q.68-R.61

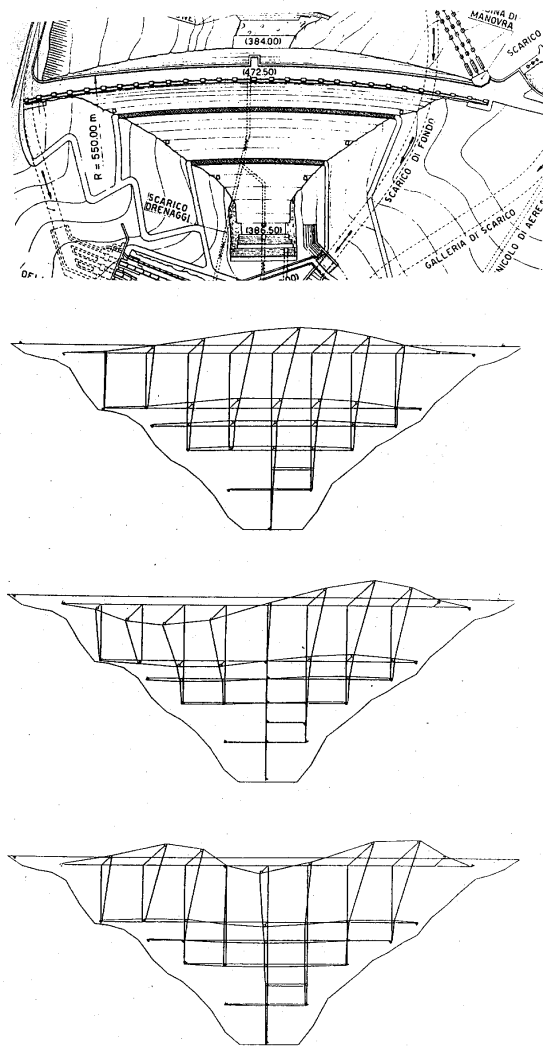

Fig 5.1: 3D behaviour of an arched gravity dam.
Dynamic mode shapes determined by forced vibration tests

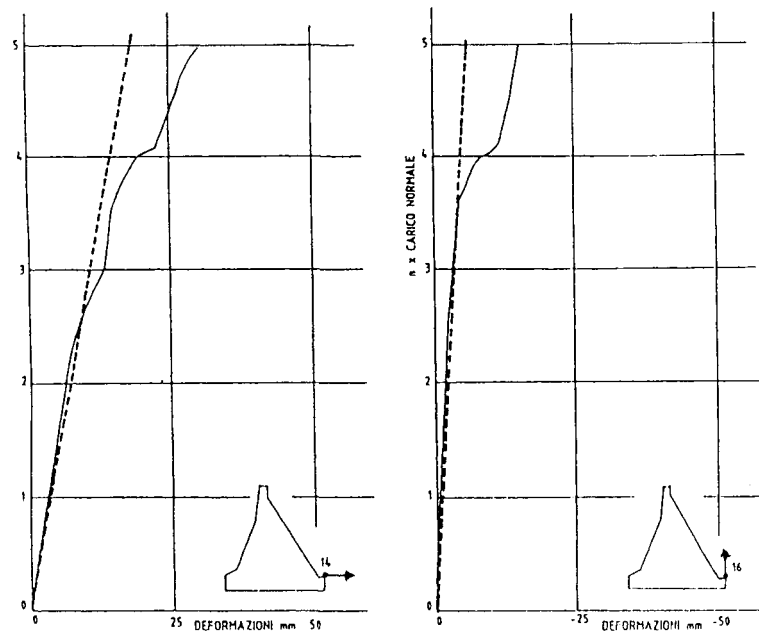
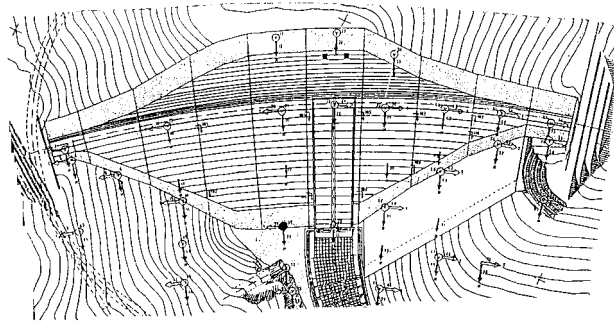
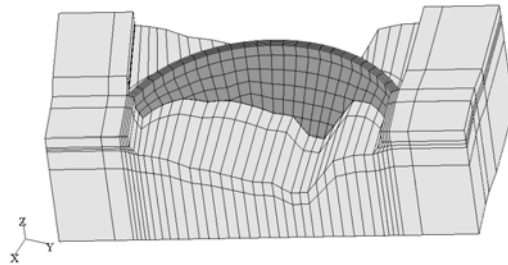
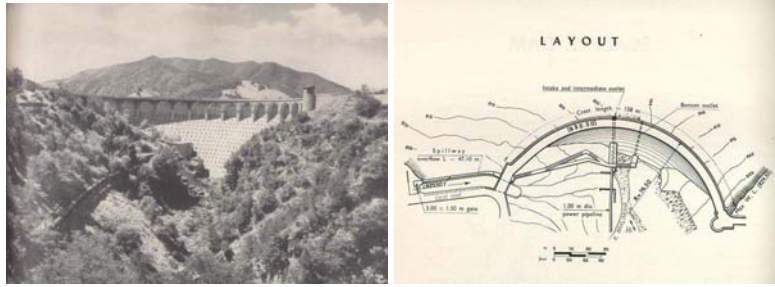
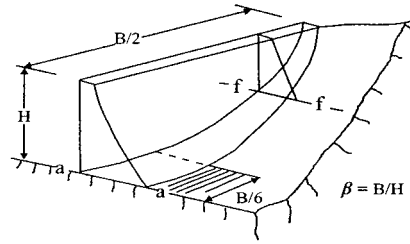

Fig 5.2 : Physical model (source: ISMES)
 Measured displacements vs. hydrostatic load amplification factor



Author	Load factor K_h Generalised sliding IFF (Imminent Failure Flood)
1	$K_h = 1.33$ Displacement not defined
2	$K_h = 1.18 - 1.21$ Max displacement (right bank) > 10mm
3	$K_h = 1.3$ Max displacement (right bank, bottom) > 25mm
4	$K_h = 1.2$ Max displacement = 2.4mm (cross section, crest), = 0.35mm (cross section, bottom)
5	$K_h = 1.28$ Displ. = 13mm (right bank, crest) , Displ. = 11mm (right bank, bottom)
6	$K_h=1.05$, Displ.=6.5mm (3-D block) $K_h=1.27$, Displ.= 4mm (3-D model)

Figure 5.3 – The 7th Benchmark Workshop (from Ref. 5.2): Selected dam; Finite element mesh for the analyses; Results



Normal stress distribution

Normal stress distribution

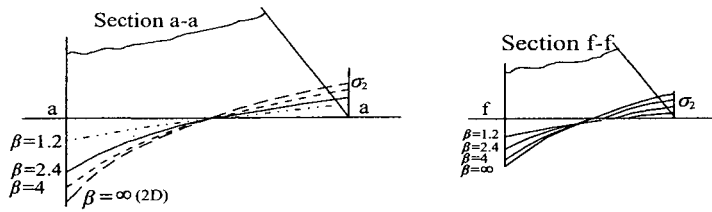

Fig 5.4: 2D vs. 3D analysis.
Normal stress distribution (from Ref 5.4)

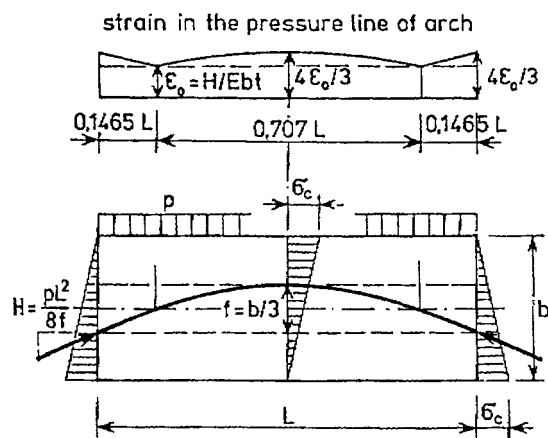

Fig 5.5 : Tension-free beams with arch action (from Ref 5.5)

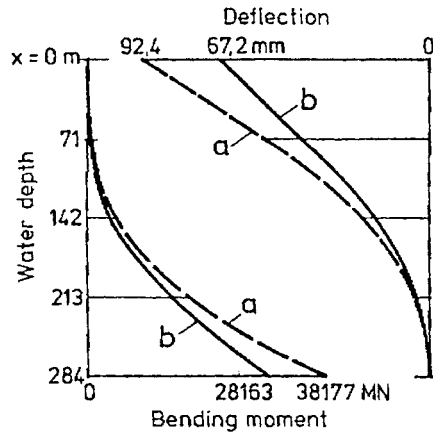

Fig 5.6: Bending moment and deflection (from Ref. 5.5).
Without (a) and with (b) 3D grid action

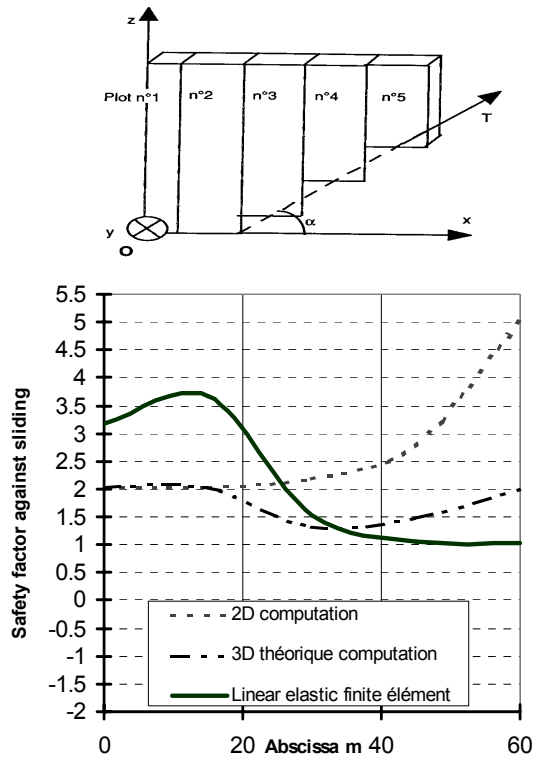

Fig 5.7: Safety factors against sliding. (from Ref. 5.7)
Comparison among different 2D and 3D approaches

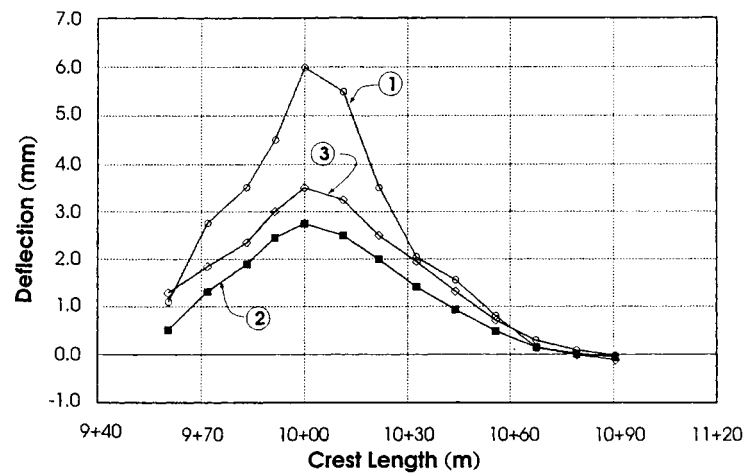
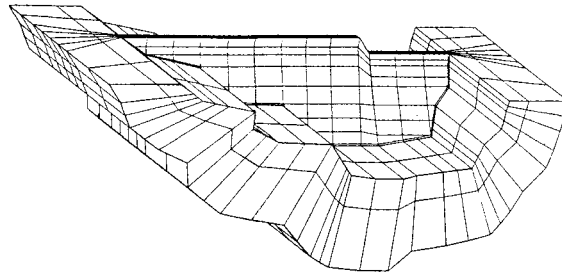

Fig 5.8 : Soha dam – Crest deflection (from Ref. 5.8).

- (1): 2D, uncracked base;
- (2): 3D, uncracked base;
- (3): 3D, cracked base

APPENDIX 1:

REGULATORY RULES, GUIDELINES, NORMAL PRACTICE

ITALY

REGULATIONS

No regulatory rules for the safety assessment of existing dams are currently available.

General regulatory rules concerning the "Design, Construction and Operation of Dams" are given in the "Dam Regulation" (D.P.R. n. 1363, 1 Nov. 1959). The technical rules to be followed for the design of dams have been updated in 1982 ("Technical Rules for the Design and Construction of Dams", D.M. 24.03.1982)

REGULATORY RULES (design phase)

The basic reference for the safety assessment of existing dams is, in normal practice, the current Dam Regulation for the Design and Construction of Dams.

Efforts are carried out to take into account the specific and actual condition of the existing dam under examination, on a case by case basis, using the available knowledge to overcome some limitations deriving from the rigid design directions defined in the Regulation. The case-by-case approach does not allow to identify alternative standards or commonly applied normal practice.

For the dam design, the assessment of the safety against sliding for gravity dams prescribed by the current Italian Technical Rules requires the calculation of the ratio T/N , where T and N are, respectively, the resultant of forces parallel and normal to the sliding surface under consideration. The assessment must be carried out examining sliding surfaces in the dam body (at any elevation) and at the dam base, considering the following loading condition: dead weight + hydrostatic loads (max design water level) + uplift pressures + ice load (when present) + seismic load (when present).

The limit values of the T/N ratio are:

- 0.75 along the whole dam height, when seismic loads are not present;
- 0.8 for sections located less than 15 metres below the crest elevation, and 0.75 for the remaining sections, when seismic loads are present.

82 SLIDING SAFETY OF EXISTING GRAVITY DAMS

These values should be reduced if the foundation conditions suggest so. In case of inclined sliding surfaces (base section, lift joints), the slope to be considered for the safety assessment can not exceed 5%. These rules apply also to buttress dams, when the ratio between buttress spacing and minimum buttress thickness (or the sum of the thicknesses if the buttresses have internal cavities) is lesser than 4.

In some cases, more physical and deep safety assessment are carried out referring to actual shear strength properties determined by tests, but the simple T/N criteria is still a reference evaluation that can not be disregarded.

G E R M A N Y

REGULATIONS

In Germany the assessment of dam safety is based upon German DIN standards. Federal state laws prescribe the use of these standards. Basic standards for dams are DIN-19700 part 10 (Dam plants – General specifications) and part 11 (Dam plants–Dams) and DIN-19702 (Stability of solid structures in water engineering).

The updating of the several parts of DIN 19700 is currently in progress.

REGULATORY RULES

The regulatory rules summarised hereinafter apply not only to the design phase but also to the safety assessment of existing dams.

According to the current draft, the updated rule DIN 19700/11 will consider the whole dam-foundation system. Consequently, not only the sliding of the dam body along the dam-foundation interface must be assessed, but also any possible sliding surfaces through the foundation have to be examined, taking into account the joints/fissures in the rock-mass.

For safety assessment, 3 groups of loading cases have to be combined with 3 “conditions of the structure” (“*Tragwerkszustand*”). The condition of the structure is determined by the characteristic values of the materials, that can be stated mostly only in scattered fields. These combinations are shown in the following table.

	Material properties		
	Best estimate values	low probability values (conservative)	Lower bound values (very conservative)
Load case 1 (1)	BF I	BFII	BFIII
Load case 2 (2)	BF II	BF III	
Load case 3 (3)	BF III		

(1): dead load, max water level, etc.

(2) : flood water level, etc.

(3) : extreme flood, earthquake

In the current draft of DIN 19700/11, in part 117.3.6.1, the following minimum safety factors are defined:

	BF I	BF II	BF III
sliding along dam-foundation interface	1,5	1,3	1,2
sliding along joints in the bedrock	2.0	1,5	1,2

The shear strength in joints or fissures can be expressed by means of a friction angle and an apparent cohesion.

For the computation of the safety factors, calculations by means of finite-element-method will be allowed.

SPAIN

REGULATIONS

General regulatory rules are given in the recent:

- "*Technical Regulation for Safety of Dams and Reservoirs*", March 1996 that updates the previous "*Instructions for the Design, Construction and Operation of Large Dams*", March 1967.

84 SLIDING SAFETY OF EXISTING GRAVITY DAMS

In the new Regulation basic safety criteria are defined to prevent and limit the potential risk to dams, but no specific technical indications are given (they are left to the responsibilities of the dam designer and dam owner). No specific criteria are given for the safety assessment of existing dams.

REGULATORY RULES AND NORMAL PRACTICE

The current Regulation prescribes that the structural safety of the dam must be assessed taking into account the different possible load factors and loading conditions. The adopted safety levels must be related to the loading condition and to its probability of occurrence and transient/permanent character, and referring to the risk category assigned to the dam. The dams are classified in three categories, depending on the dam hazard (potential damages and casualties in the downstream areas affected by a possible dam collapse or incidents)

For the safety assessments, Normal, Abnormal, and Extreme loading conditions must be taken into account. These loading conditions must be defined by the designer, according to general directions given in the Regulation.

Referring to the uplift factor, which strongly affect the sliding safety assessment, an abnormal increase of the pore pressures (uplift) should be considered in the Abnormal Conditions.

The possibility of a abnormal general reduction of the strength parameters should be considered, as an the Extreme Condition.

The current normal engineering practice derives from the more detailed technical directions defined in the 1967 Regulation ("*Instructions para el proyecto, construction y explotación des grandes presas*"). In that Regulation the loading conditions were specified, subdivided in Normal Conditions and Abnormal Conditions (seismic loads, maximum flood, drainage deterioration).

The safety assessment refers to a limit equilibrium approach (driving forces compared with resisting forces). The given safety factors correspond to reduction factors to be applied to the shear strength parameters (cohesion 'c' and friction angle ' Φ ')

For the Normal Loading Conditions (two, identified as A1: empty reservoir, and A2: full reservoir) and Abnormal Loading Conditions (four, identified as B11, B21, B22, e B23), the following safety factors (reduction factors) are defined:

Loading Condition	Strength Reduction Factor	
	Friction Φ	Cohesion c
Normal	1,5	5
Abnormal	1,2	4

Any weak layer (lift joints, dam - foundation contact surface, joints in the foundation) must be considered in the safety assessment.

PORTUGAL

REGULATIONS

Regulatory rules concerning dam safety assessment are given in the "Regulation for the Design of Dams", n. 846/93, September 1993.

REGULATORY RULES

The Regulation provide directions about the load factors to be considered in Construction, Operational (Normal) and Extreme (exceptional floods, earthquakes, etc.) loading combinations.

For Normal loading conditions an essentially elastic response of the dam-foundation system should be assessed. For Extreme loading combinations adequate safety factors against failure condition should be assessed.

A general reference is made to linear or non-linear structural models of the dam-foundation system for the structural evaluation and safety assessment, and to the examination of the mechanical effects of the water in terms of effective stresses, taking into account the water flow through material pores, joints or cracks, and the associated actions. Numerical hydraulic models must be used for the evaluation of the water flow and pressure gradients.

For stability analyses, it is explicitly stated that mass forces due to the water flow can be replaced by surface forces, considering them acting on the boundary surfaces of the examined system. (upstream face, grout curtain, joints, ...), taking into account the effect of the drainage system.

The safety factors defined in the Regulation correspond to reduction factors to be applied to the shear strength parameters

In Normal loading combinations:

- The stresses in the dam body, either in volumetric elements or along joints, in spite of any localised failure, must satisfy Mohr-Coulomb criteria

86 SLIDING SAFETY OF EXISTING GRAVITY DAMS

for tensile and compressive peak strengths using safety coefficients between 2.5 and 4.

- The stresses in the foundation, either in volumetric elements or along joints or other weak surfaces, in spite of any localised failure, must satisfy Mohr-Coulomb criteria using safety factors between 3 and 5 for cohesion peak strengths (c_p) and between 1,5 and 2 for the friction coefficient (Φ_p).

In Extreme loading combinations:

- The stresses along global failure surfaces must satisfy Mohr-Coulomb criteria, for a situation of no cohesion and using safety factors between 1,2 and 1,5 for the residual friction coefficient (Φ_r).

Resuming, for Normal and Exceptional loading combinations the following safety factors (strength reduction factors) are defined for the safety assessment against sliding:

Loading Condition	Strength Reduction Factor			
	Φ_p	c_p	Φ_r	c_r
Normal	1,5 - 2	3 ÷ 5		
Extreme			1,2 - 1,5	$c_r = 0$

CHINA

REGULATIONS

The Chinese Technical Standards on subjects related to hydropower engineering are very numerous.

The list of those published in the period 1990-1999 contains more than 140 documents (most of them related to electrical and mechanical equipment).

In September 2000 "The Standard Compilation of Water Power in China", in English language, was published. It contains the Chinese Technical Standards related to:

- Unified Design Standard for reliability of hydraulic engineering structures (GB 50199-1994)
- Design code for loads on Hydraulic structures (DL 5077-1997)
- Seismic Design Code for hydraulic structures (DL 5073-1997)

- Design Code for concrete face rockfill dams (DL/T 5016-1999)
- Design Code for concrete gravity dams (DL 5108-1999)

The Unified Design Standard (GB 50199) was worked out in order to unify basic principles and standards for the design of hydraulic engineering structures. It formulates common criteria, which all design codes of hydraulic structures shall comply with.

The other listed Design Code deal with specific design subject.

Details about the assessment of the safety against sliding for gravity dams are given in the Design Code DL 5108-1999

REGULATORY RULES

The Unified Design Standard is based on principles of probabilistic theory and limit states design. The limit states design with partial coefficients is defined as practical design method.

Hydraulic structures must be designed for the load bearing capacity ultimate limit states (ULS) and the normal operation limit states (NOLS).

The assessment of the safety against sliding is identified as a USL assessment (limit state of load bearing capacity).

Deformations which affect the normal operation or appearance of the structure, or local damage affecting appearance and durability of the structure and impermeability of watertightness elements, correspond to normal operation limit states.

The different load factors have to be combined according to given rules, and the loading combinations are derived for the following conditions:

- Basic combination, sustained status: ULS assessment, NOLS assessment
- Basic combination, transient status: ULS assessment, NOSL assessment if necessary
- Occasional combination: USL assessment

Ultimate Limit State assessment

In general terms the USL assessment can be expressed by the following expression

$$\gamma_0 \Psi S(\gamma_G G_k, \gamma_Q Q_k, A_k) \leq 1/\gamma_d R (f_k / \gamma_m)$$

where:

88 SLIDING SAFETY OF EXISTING GRAVITY DAMS

- γ_o = importance factor of the structure ($\gamma_o = 1.1 - 1.0 - 0.9$)⁸.
- Ψ = factor of design status ($\Psi = 1.0 - 0.95 - 0.85$)⁹
- S = effect of the loading actions
- G_k = standard values of the permanent loads
- γ_G = partial coefficient for the permanent loads G_k ¹⁰
- Q_k = standard values of the variable loads
- γ_Q = partial coefficient for the variable loads Q_k ³
- A_k = typical value of the occasional load

- γ_d = structure coefficient¹¹
- R = strength
- f_k = standard value of the material property
- γ_m = partial factor of the material property

For the assessment of the limit state of sliding-resistance stability a rigid body limit equilibrium approach is used, evaluating the total driving force and the total strength along the surface under examination (if necessary, FEM and geological mechanic model test methods could be used, in addition to the rigid body limit equilibrium method)

The safety assessment must be carried out examining:

- lift joints in the dam concrete body
- dam to foundation contact surface

⁸ Water conservancy and hydropower projects are classified in accordance with a "Classification Table", based on their scales, benefits and importance in national economy, in five ranks (from class I to class V). Hydraulic structures are consequently classified ("Grade of the Structure") in accordance with a further "Classification Table", on the basis of the rank of the project in which they work and of their role and importance in the project. Different "Safety Grades", from I to III, are then associated to the different Grade of the Structure and used for the design of gravity dams.

The γ_o coefficient is related to the Safety Grade ($\gamma_o = 1.1 - 1.0 - 0.9$ for Safety Grade = I - II - III))

⁹ The value of the Ψ coefficient is related the loading condition:

- Basic combination (permanent and variable actions), sustained status : $\Psi = 1.0$
- Basic combination (permanent and variable actions), transient status : $\Psi = 0.95$
- Occasional combination (one occasional actions, under fortuitous status): $\Psi = 0.85$

¹⁰ The γ_G and γ_Q coefficients are defined in a given Table, for each different load. They range between a min. value 1.0 (dead load, hydrostatic pressure,...) and a max. value 1.3 (hydro-dynamic pulsating pressure).

¹¹ For sliding stability limit state the structure coefficient $\gamma_d = 1.2$, both for basic and occasional loading combination.

- deep stratum in the foundation when there exist soft and weak structural planes, low dip angle fissures or exposed surfaces caused by downstream scouring.

The total strength is evaluated by means of the classical expression based on cohesion and friction coefficient.

The evaluation of the standard values for the shear strength parameters (cohesion and friction angle) may be carried out at different precision level, depending on the design stage and on the importance of the dam.

In any case, a probabilistic normal distribution model for the friction coefficient and a logarithmic normal distribution model for the cohesion will be assumed.

In feasibility study for large projects or in design phase for medium projects, testing results of similar projects or standard values given in Annex D of the Design Code for Concrete Gravity Dams could be adopted.

For the shear strength parameters the following partial factor of the material property (γ_m) are to be used:

Surface	Partial Factor (γ_m)	
	Friction (γ_f)	Cohesion (γ_c)
Concrete/concrete	1.3	3.0
Concrete/bedrock	1.3	3.0
Bedrock/bedrock	1.4	3.2
Soft - weak structural plane	1.5	3.4

UNITED KINGDOM

REGULATIONS

In UK the assurance of dam safety is based on the Reservoirs Act 1975.

This requires the appointment by dam owners of a suitably qualified engineer to supervise the design and construction of any new dam or remedial works affecting dam safety, and to review the safety of each existing dam at not more than 10-year intervals. Others are charged with supervision between these inspections. Lists of qualified engineers are held,

90 SLIDING SAFETY OF EXISTING GRAVITY DAMS

reviewed at intervals and updated on behalf of the government by a committee of the Institution of Civil Engineers. There are about 50 engineers qualified as Construction and Inspecting Engineers under the Reservoirs Act.

There are no regulations on technical matters relating to dam design, individual qualified engineers being expected to draw on best current practice for appropriate design methods and criteria to suit particular circumstances. However a series of engineering guides relating to reservoir safety, prepared with a combination of industry and government funding, have been published over the past 10 years.

The guide relating to concrete and masonry dams is the “*Engineering guide to the safety of concrete and masonry dam structures in the UK*”, by M F Kennard, C L Owens and R A Reader, CIRIA Report 148, 1996. ISBN 086017-432-8. ISSN 0305 408 X.

This refers particularly to existing dams rather than design of new dams. It specifically states that it is non-prescriptive and is not a code of practice.

REGULATORY RULES

The relevant extract from the above guide states:

“4.2.11 Sliding of the structure ”

A gravity dam must be analysed to ensure a factor of safety against sliding downstream under the horizontal forces imposed upon it. Sliding can be analysed in several ways, but the shear-friction factor of safety indicates the degree of safety against sliding or shearing at any level.

Shear friction is analysed on a near horizontal plane (usually sloping upwards in a downstream direction if lift joints are inclined in this direction) by summing the total resistance that can be mobilised against shear and sliding, and dividing by the total load in the direction of the plane of sliding to give the factor of safety. *Design of Small Dams*, 1987, gives the following recommended shear-friction factors of safety:

<u>Shear friction</u>	Loading Conditions		
	Usual	Unusual	Extreme
Mass concrete	3.0	2.0	Over 1.0
Concrete interface	3.0	2.0	Over 1.0
Rock foundation	4.0	2.7	1.3

The analysis can include (if appropriate) the resistance from the rock wedge at the downstream toe of the dam.

CANADA

REGULATIONS

Dam Safety Guidelines have been issued in 1995 by the Canadian Dam Safety Association.

The Guidelines have the objective to define requirements and outline guidelines so that the safety of existing dams can be investigated and identified in a consistent and adequate manner across Canada, to facilitate the transfer of information and standards of practice among professional engineers, to provide a basis for dam safety legislation and regulation.

Therefore the Guidelines are not regulatory Rules. They are not intended as design specifications for dam safety evaluation, design, construction or rehabilitation.

NORMAL PRACTICE

The level of safety assessment for concrete dams shall take into account the consequences of failure of the structure. Very low consequences structures may be exempted from the technical requirements presented in the Dam Safety Guidelines.

For the safety assessments, Usual, Unusual, and Exceptional loading conditions must be taken into account.

- Usual loading condition: permanent and operating loads (self-weight, normal maximum operating water level, uplift pressures, tailwater level, ambient temperatures, ice, silt, earth pressure).
- Unusual loading condition: where earthquake-induced cracking at the rock-concrete interface or any weak section is identified, a stability analysis shall be carried out to see whether the structure in its post-earthquake condition is still capable of resisting the Usual Loading. An inoperative drain case assuming plugged drains may be assessed and taken as an Unusual Loading case.
- Flood Loading condition: permanent and operating loads, except for ice loading, shall be considered in conjunction with reservoir and tailwater levels and uplift resulting from the passage of the Inflow Design Flood.
- Earthquake Loading condition: Permanent and operating loads shall be considered in conjunction with the Maximum Design Earthquake.

92 SLIDING SAFETY OF EXISTING GRAVITY DAMS

The safety assessment against sliding for concrete gravity dams and are assessed on the basis of the following performance Indicators:

- Average shear stresses acting on the surface
- Calculated sliding factors and strength factors
- Observed conditions of structure and site

Shear Stresses

The shear stresses, computed assuming the driving force uniformly distributed over the zone of calculated compression, should be compatible with the available Shear Strengths.

This criteria is aimed to guard against the tendency for the concrete to potentially begin forming a series of diagonal tension cracks in areas of much higher than the average shear stress (usually near the heel of the dam)

Sliding Factors

The resistance of a gravity dam against sliding on any surface is assessed by comparing the Net Driving Force with its Available Shear Strength. The ratio of the Available Shear Strength and the Net Driving Force is referred to as the Sliding Factor (SF):

$$SF = \frac{\text{Available Shear Strength}}{\text{Net Driving Force}}$$

The net driving force is the sum of tangential components of all forces acting above the sliding surface.

The potential sliding surface is not necessarily horizontal and special attention should be paid to shallow upstream dipping/daylighting and downstream dipping surface geometry, where gravity contributes to the driving force.

For multiple sliding planes, warped sliding surfaces and other complex geometry of any foundation failure surface, special care must be taken to establish the net driving force and the available sliding resistance.

Shear Strength

In general practice, the shear strength in both cases are based on Mohr-Coulomb criteria and consist of the frictional and the cohesion components.

Two states of available shear strength (peak, residual) should be considered:

- Peak shear strength = $\Sigma A_c (S_n \tan \Phi' + \tau_0)$
- Residual shear strength = $\Sigma A_c (S_n \tan \Phi'' + \tau_n)$

A_c = compressed area

S_n = normal stress

Φ' = angle of internal friction (peak)

τ_0 = threshold shear strength at zero S_n (cohesion)

Φ'' = angle of sliding friction (residual)
 τ_n = nominal residual shear strength¹²

Concrete

For Peak Shear Strength, if tests on concrete are not available, τ_0 values of $0.17\sqrt{f_c}$ Mpa (f_c : compressive strength of the concrete) may be used for the concrete mass.

Unless there are indications of poor quality lift joints, τ_0 values for the lift joints may be taken to be half of those used for the concrete mass.

The corresponding Φ' and Φ'' values may be taken as 55° and 45° respectively.

Values of Φ' , Φ'' and τ_0 may be obtained from triaxial or direct shear tests for the applicable normal stress range after due allowance is made for size effect, or they may be adopted from the Guidelines.

A word of caution is in order if the postulated sliding surface is considered to be along a lift joint or concrete/rock interface which may have been treated with cement-water slurry "bonding coat". Depending on the thickness of application of this "bonding coat", shear stress may only be as large as the frictional strength of the coating without the threshold shear strength normally available and relied upon elsewhere between joints. Horizontal core borings and direct shear tests are suggested in such cases.

This type of test may also be advisable for joints where it is suspected that seepage may have caused the joint strength to reduce below acceptable levels.

Concrete/rock interface

The strength depends on the following parameters: condition of the foundation rock and concrete, roughness of the excavated surface, base friction angle of the two materials, stress distribution along the contact.

Reference is made to a methodology and testing program (Lo et al., 1991) to determine the strength parameters of concrete/rock contacts. For bonded contacts, the method enables the establishment of a complete strength envelope, from tensile to compressive stress regime.

The testing method also permits the independent measurements of the basic friction angle and the surface roughness.

Rock foundation

¹² Value up to 100 kPa, if supported by tests. Without tests, it should be considered to be zero.

The strength of a rock foundation can be expressed either by the shear strength of a single discontinuity (where the foundation is dominated by well defined controlling joint sets) or by the strength of the rock mass evaluated in a gross scale.

- *Shear strength of Discontinuities*

The shear strength along a single joint of plane of weakness can be obtained either by field and/or laboratory testing or by estimation using field data.

In addition to the Mohr-Coulomb criteria, reference is also made to two other semi-empirical approaches commonly used to estimate the shear resistance along a discontinuity.

The first approach is based on the joint roughness (J_r) and joint alteration (J_a) parameters, and the shear strength is expressed as: $\tau = \sigma_n \text{tg}(J_r/J_a)$, where σ_n is the effective normal stress.

The second approach is based on the joint roughness coefficient (JRC) and the joint wall compressive strength (JCS), and the shear strength is expressed as: $\tau = \sigma_n \text{tg}(\text{JRC} \log_{10}(\text{JCS}/\sigma_n) + \Phi_r)$, where Φ_r is the residual friction angle.

- *Rock mass strength*

Reference is made to empirical failure criteria based on a large number of laboratory tests (Hoek and Brown, 1980-1988, for isotropic rock; Amadei, 1988, for anisotropic condition).

Acceptance Criteria

Adequate sliding resistance is normally indicated by sliding factors which equal or exceed the following minimum values :

Type of analysis [a]	Load Case			
	Usual	Flood	Unusual (Post-earthquake)	Earthquake [b]
Peak Sliding Factor (PSF) - No tests	3.0	2.0	2.0	1.3
Peak Sliding Factor (PSF) - With tests [c]	2.0	1.5	1.5	1.1
Residual Sliding Factor (RSF) [d, e]	1.5	1.3	1.1	1.0

[a] PSF is based on the peak shear strength. RSF is based on the residual or post-peak strength.

- [b] The stated value under the Maximum Design Earthquake (MDE) load case is based on pseudo-static analysis. Performance evaluation of the dam should also take into consideration the time-dependent nature of earthquake excitations and the dynamic response of dam.
- [c] Adequate test data must be available through rigorous investigation carried out by qualified professionals.
- [d] If PSF values do not meet those listed, the dam stability is considered acceptable provided the RSF values exceed the minima.
- [e] The minimum values of RSF shall not be reduced any further regardless of availability of data.

For dams in relatively narrow canyons (width/height ratio less than about 3.0), beneficial three-dimensional effects could be present. If beneficial three-dimensional effects are demonstrable, the stated sliding factors are not true indicators of stability.

The minimum acceptable Sliding and Strength Factors for the post-earthquake conditions are not intended for long term application. Thus, provisions should be made to inspect the dam promptly after a mayor earthquake, to monitor its behaviour and to make any necessary repairs within a reasonable period of time. The reservoir could be operated temporarily, if required, at a reduced level until repairs are made and/or safety of the dam is confirmed by analysis.

The Sliding Factors provide a measure of safety margin but they are not to be taken as absolute indicators of safety; rather they are indices that facilitate comparison of gravity dam sections on a consistent basis.

In the calculation of resistance to sliding it is advantageous to recognise the relative stiffness of all contributing components, as the stiffer ones are more likely to be mobilised first under the loads.

USA - Bureau of Reclamation

REGULATIONS

Several Federal Agencies operate in USA. Consequently, several standards of practice are applied. As an example, the guidelines used by the Bureau of Reclamation is synthesised hereinafter.

The criteria applied by the Bureau of Reclamation for the safety assessment of gravity dams, referring to the design phase, are reported in "Design

Criteria for Concrete Arch and Gravity Dams", Engineering Monograph n. 19, 1974.

NORMAL PRACTICE

The criteria applied by the Bureau of Reclamation for the dam safety assessment are based on the use of safety factors which are considered to provide for all underlying uncertainties and should be used without additional provision for safety, except under conditions of unusual uncertainty or hazard.

For the safety assessments, Usual, Unusual, and Extreme loading conditions must be taken into account. (and any other loading combination which, in the designer's opinion, should be analysed for a particular dam).

- Usual loading combinations : Normal design reservoir elevation with appropriate dead loads, uplift, silt, ice, tailwater, and temperature if applicable
- Unusual loading combinations : Maximum design reservoir elevation with appropriate usual loads
- Extreme loading combinations - Usual loading plus effects of the "Maximum Credible Earthquake"

The Usual and the Unusual loading combination should be examined also assuming that the drains are not operative.

Material properties

Concrete

Appropriate tests should be made to determine the strength values. For preliminary designs, until test data are available, values of concrete properties may be estimated from published data, or the following average values for concrete properties may be used:

- Tensile strength: 5-6 % of the compressive strength;
- Cohesion: about 10 % of the compressive strength;
- Coefficient of internal friction: 1.0

Foundation

Resistance to shear within the foundation and between the dam and its foundation: laboratory and in situ tests are carried out to obtain a shear resistance versus normal load relationship for each material along the possible sliding planes. The shear resistance obtained as above should be limited to the range of normal loads used in the tests.

The scale effect should be carefully considered in determining the values of shear resistance to be used

The results of laboratory triaxial and direct shear tests, as well as in situ shear tests, are generally reported in the form of the Coulomb equation: $R = CA + N \tan \phi$. Although this assumption of linearity is usually realistic for the shear resistance of intact rock over the range of normal loads tested, a curve of shear resistance versus normal load should be used for materials other than intact rock.

The displacement used to determine the shear resistance is the maximum displacement that can be allowed on the possible sliding plane without causing unacceptable stress concentrations within the dam.

Effects of treatment on foundation properties should be considered

Sliding stability

The shear-friction factor of safety provides a measure of the safety against sliding or shearing on any section. The following expression is the ratio of resisting to driving forces and applies to any section in the structure or at its contact with the foundation for the computation of the shear-friction factor of safety,

$$Q = (CA + (\Sigma N + \Sigma U)\tan\phi) / \Sigma T,$$

- C = cohesion
- A = area of section considered
- ΣN = summation of normal forces
- ΣU = summation of uplift forces
- $\tan\phi$ = coefficient of internal friction
- ΣT = summation of shear forces

Although somewhat lower safety factors may be permitted for limited local areas within the foundation, overall safety factors for the dam and its foundation should meet the following requirements:

Sliding surface	Loading Combination		
	Usual	Unusual	Extreme
Concrete-Concrete	3	2	1
Concrete - Foundation	3	2	1
Within the foundation	4	2.7	1.3

For other loading combinations where safety factors are not specified, the designer is responsible for selection of safety factors consistent with those for loading combination categories previously discussed.

SWITZERLAND

REGULATION

The legal basis for the safety of reservoirs and dams in Switzerland is included in the article 3bis of the federal law of the 22nd June 1877 on water policies (RS 721.10) and the Ordinance of the 7th December 1998 on the safety of Storage Structures (OSOA, "*Ordonnance sur la Sécurité des Ouvrages d'Accumulation*").

The ordinance fixes the requirements for the safety of all of the storage structures, both new or existing.

For structural safety, Article 3 point 1 of OSOA only points out that: "Storage structures must be dimensioned and built considering the actual techniques so that the safety will be assured in any foreseeable load case during use period".

Structural safety will be evaluated to guarantee the performance of the dam under different types of load: permanent, variable, exceptional and accidental.

Different serviceability levels have to be considered as: threshold levels of the water in the reservoir, aspects induced by the serviceability breakdown caused by a revision of electro-mechanic equipment, spillway and outlet structures breakdown, turbine maintenance, etc.

There are no general rules, regulations or standards; a autonomy is given to the engineer that has to comply with the requirements of above mentioned article 3.

GUIDELINES

The ordinance on the safety of storage structures allows the Federal Office of Water and Geology to prepare guidelines in junction with representatives of the cantonal authorities, of scientific spheres, of professional's society and economist's organisations (Art. 26 OSOA).

The Guidelines are under development, and are currently available in preliminary version.

The primary target of these guidelines is to provide the procedures to apply the different articles of the Ordinance on Safety of Storage Structures. The guidelines show the state of the art to be applied in the dam safety domain in Switzerland, by keeping into account the actual state of the scientific knowledge. These include the basic elements to ensure the safety of storage structures.

Guidelines are more restrictive than recommendations, but not as mandatory as ordinances. It is possible to derogate somehow from the guidelines by demonstrating that the ordinance safety requirements are matched at least equivalently.

Different types of loads that play a role in the safety analysis are given hereinafter. The guidelines dealing with structural safety, flow safety and seismic safety give precise information about loads and their evaluation.

- Permanent loads: these loads act at all times. It is anyway possible that they arise after some time of operation and since their occurrence, they act without modification. They include: weight, sediment pressure, earth pressure, hydrostatic pressure and uplift pressure (if the reservoir is always full).
- Live loads : these loads vary according to the operation conditions, and to climate natural conditions. They include: hydrostatic pressure, uplift pressure, temperature, snow, ice load, sediment pressure, earth pressure, rolling loads and other loads.
- Exceptional loads: these loads are induced by exceptional events that can be intense. Their effects can be instantaneous or of limited duration. They include: Flood, Earthquake, Avalanche, Lava flowing.
- Incidental loads: Explosion

The following load combinations are kept into account:

- Normal situation : includes loads that normally load the structure.
- Exceptional situation: includes exceptional loads that may occur during structure lifetime
- Extreme situation: includes the most severe load cases that the structure may experience.

Sliding stability

Generally the safety assessment consists in the control of the stability against sliding, against overturning and if the case, against uplifting. Sliding stability is defined by a ratio between sum of vertical forces and sum of horizontal forces. It has to be pointed out that the position of the resulting force and the value of the tensions upstream are also to be assessed.

100 SLIDING SAFETY OF EXISTING GRAVITY DAMS

Stability against overturning is defined as the ratio between the stabilising and overturning moment.

Stability against uplift is defined as ratio between the vertical forces oriented down and vertical forces oriented up. This is often to be verified in the case of “light dams”, as the river dams

The safety assessment for sliding is based on :

- the internal friction angle φ ,
- the cohesion c (eventually)

and the following relationship is checked:

$$FS = \frac{(\tan(\varphi) \cdot \sum V) + c \cdot A}{\sum H}$$

FS : safety factor.

ΣV : sum of all vertical forces acting on foundation level or at the level of the assumed sliding surface.

ΣH : sum of all the horizontal forces acting above foundation level or at the level of the assumed sliding surface.

A : Area of the dam-foundation contact surface, or of the assumed sliding surface.

Φ : internal friction angle

c : cohesion.

In principle the cohesion can be considered only if really mobilised, and if the internal friction angle is low. To assess the value of cohesion, tests are necessary, or one can base on values given in literature.

The sliding surfaces assumed have to account for the geological structure of the foundations, the φ and c will also depend on the conditions of the sliding layer.

About safety factors the following values can be assumed, if a zero cohesion is assumed:

Type of load		
Normal	Exceptional	Extreme
1.5	1.3	1.1

If cohesion is taken into account, minimum safety factors against sliding have to be increased to account for the risk of a reduction of the cohesion

due to the movement. The FS minimal values will be respectively 5,4, and 3.

Is also possible to assume partial safety factors, adopting the following relationship:

$$\sum H < \frac{\tan(\varphi) \cdot \sum V}{FS_1} + \frac{c \cdot A}{FS_2}$$

FS1 : is equal to FS if a zero cohesion is assumed

FS2 : is equal to 5, 4 or 3, according to the type of load (normal, exceptional or extreme)

FRANCE

REGULATIONS

A "Gravity Dams Working Group" of the French Committee on Large Dams has recently reviewed leading reference works and practices applied in France for the deterministic gravity dams analysis.

The information reported hereinafter are derived from the report of this Working Group (January 2002).

There is no standard neither regulation in France concerning stability analysis of dams. The current practice derive from the following references:

- a) *Technique des barrages en aménagement rural - Ministère de l' Agriculture*, 1989.
- b) *Petites barrages - Recommandations pour la conception, la réalisation et le suivi*. Cemagref ENGREF/CFGB, Paris 1997.
- c) EDF Practice.
- d) Coyne & Bellier practice.

Noting those different practices, the French Committee on Large Dams has given a second mandate to the "Gravity Dams Working Group". This mandate is to harmonise the French practices and to converge to Guidelines for the stability assessment of gravity dams (to be published under the auspices of French COLD). These Guidelines will be at the deterministic format, but will adopt concepts issued from the semi-probabilistic format (terminology, notations, loading situations, actions, resistance, etc). It is scheduled to complete this work beginning of 2005.

NORMAL PRACTICES

For the safety assessments, Usual, Unusual, and Extreme loading conditions are taken into account in Ref. b), c) and d).

102 SLIDING SAFETY OF EXISTING GRAVITY DAMS

- Frequent or Quasi-permanent (Usual) loading combinations : Normal design reservoir elevation with appropriate uplift and other usual permanent loads
- Rare (Unusual) loading combinations : Maximum design reservoir elevation with appropriate usual loads.
- Accidental (Extreme) loading combinations - Usual loading plus seismic effects.

In Ref. a), reference is made to two loading combinations only: Usual and Exceptional

Material properties

Dam Body

For conventional concrete, shear strength properties (c , ϕ) can be obtained from laboratory testing (from the intrinsic curves for the material). Correlation between shear strength parameters and the tensile/compressive strength may be used.

For stone masonry dam, the tensile strength and the cohesion are generally taken as zero.

For roller compacted concrete dam, materials laboratory tests are not necessarily representative of the RCC lift interface parameters. Careful scrutiny of the construction specification for the RCC layers is vital for determining shear strength parameters.

Dam Foundation interface

In a first conservative approach, interface cohesion is taken as zero, because of the disturbance caused by the excavation works, and the friction angle may be taken as 45° (for a sound rock-dam interface). If special procedures were applied for the preparation of the surface (careful work, undamaged foundation) the cohesion and the friction angle at the interface can be assumed as the minimum between the values for the concrete and for the foundation.

Foundation

The most satisfactory way to determine the cohesion and internal friction angle is to examine the intrinsic curves for the rock materials. The Barton and Hoek curves are the basic reference. The intrinsic curves is not a straight line. The curve for a given range of normal stresses can be approximated to a straight line. Friction angle and cohesion can be conservatively estimated by the secant through the two points corresponding

to the stress range considered. Foundation cohesion in the low stress range is usually taken as zero, especially when designing new dams.

Sliding stability

Technique des barrages en aménagement rural, 1989

The sliding criterion adopted in Ref. a) ensures the dam will not slide along its foundation. The following expression is used for the computation of the shear-friction factor of safety:

$$F = (C \cdot L + (N - U) \cdot \text{tang}\phi) / T$$

- C = cohesion
- tang ϕ = coefficient of internal friction
- L = length of the section
- N = normal forces
- U = uplift forces
- T = shear forces

The following minimum values for the factor of safety are defined:

Surface	Loading Combination	
	Usual	Exceptional
Dam-foundation interface	4	2.7

Petites barrages - Recommendations, 1997

As in Ref. a), the sliding criterion adopted in Ref. b) ensures the dam will not slide along its foundation. For the factor of safety the same expression given for Ref. a) is used, but the cohesion is taken as zero.

Correspondingly, the expression for the shear-friction factor of safety is:

$$F = (N - U) \cdot \text{tang}\phi / T$$

The following minimum values for the factor of safety are defined:

Surface	Loading Combination		
	Usual	Unusual	Extreme
Dam-foundation interface	1.5	1.5	1.3

104 SLIDING SAFETY OF EXISTING GRAVITY DAMS

EDF Practice

The shear-friction factor of safety provides a measure of the safety against sliding or shearing on any section (in the dam body, at the dam-foundation interface, in the foundation). The usual expression is used for the computation of the shear-friction factor of safety:

$$F = (C \cdot L + (N - U) \cdot \tan\phi) / T,$$

- C = cohesion along the crack-free part of the section
 L = length of the crack-free part of the section

The safety factors should meet the following requirements:

Surface	Loading Combination		
	Usual	Unusual	Extreme
Concrete-concrete. Dam-foundation interface. Foundation.	1.33	1.10	1.05

Coyne & Bellier Practice

Drawn from the Indian Standards, the Coyne & Bellier practice consider different safety factors for the cohesion and friction parameters. The following expression is used for the computation of the shear-friction factor of safety (with the same notations as above):

$$F = \left[\frac{\tan(\phi) \cdot (N - U)}{F_\phi} + \frac{c \cdot L}{F_c} \right] * \frac{1}{T}$$

- F_ϕ = partial factor of safety in respect of friction,
- F_c = partial factor of safety in respect of cohesion.

The following values of the partial safety factors are used :

Loading Combination	Usual	Unusual	Extreme
F_ϕ	1.5	1.2	1
F_c	3	2	1

Cohesion is considered only if no shear is admitted during all the life of the dam.

For usual and unusual loading combinations, F must be higher than 1.

For extreme loading combinations (seism), F could be smaller than 1, but shearing displacements must be evaluated (i.e. Newmark method) and after seism stability for usual and unusual combination must be verified assuming $c=0$.

NORWAY

REGULATIONS

The Norwegian Regulation is under preparation.

REGULATORY RULES

The information given hereinafter have been derived from the draft Regulation currently (May 2002) under discussion.

Safety against sliding is assessed by proving that horizontal loads can be transferred from the dam body construction to the foundation. This assessment shall be carried out on sliding planes in the dam, at the dam-foundation contact surface, and in the foundation.

The inclination of the sliding plane shall be taken into account.

The factor of safety against sliding, 'S', is given by: $S = F/\Sigma H$

where:

- F : maximum shear resistance which can be mobilized
- ΣH : sum of horizontal loads

The maximum shear resistance which can be mobilized is given by the equation:

$$F = \frac{cA}{\cos \alpha (1 - \operatorname{tg} \varphi \cdot \operatorname{tg} \alpha)} + (N - U) \operatorname{tg}(\varphi + \alpha)$$

where:

- φ : angle of friction
- α : inclination of the sliding plane in relation to the horizontal
- c : cohesion
- A : area in compression
- U : force due to uplift pressures
- N : normal force on the sliding plane
- ΣV : N-U sum of vertical forces
- ΣH : sum of horizontal forces

When $\alpha = 0$ (horizontal sliding plane) 'F' and 'S' reduced to:

$$F = cA + \Sigma V \operatorname{tg} \varphi$$

106 SLIDING SAFETY OF EXISTING GRAVITY DAMS

$$S = \frac{cA + \sum V \cdot \operatorname{tg} \phi}{\sum H}$$

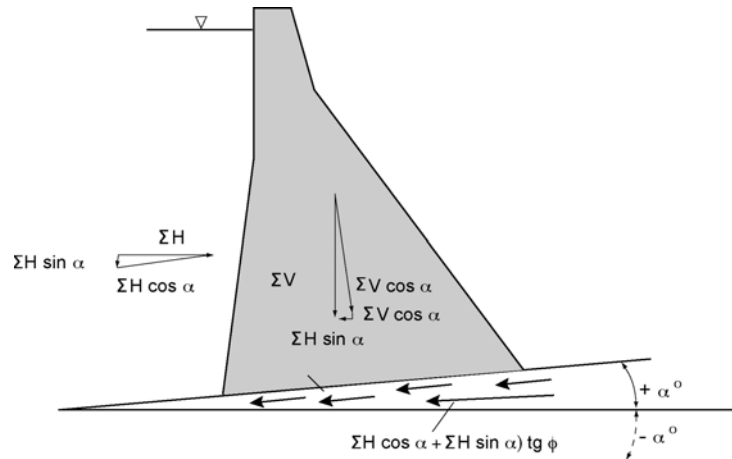

The contribution from cohesion at the dam-foundation interface shall not be taken into account when calculating total resistance against sliding, unless confirming such shearing contribution through tests.

As regards the sliding along badly prepared lift joints, cohesion contribution shall not be taken into account.

For well prepared lift joints without general cracking in the concrete, a maximum cohesion contribution of $0.085\sqrt{f_{cd}}$ (MPa) may be taken into account without confirmation through tests (f_{cd} : compression strength of the concrete).

When cohesion is not taken into account, the safety factor S shall be at least

- 1.5 for design loads
- 1.1 for unusual and extreme loads.

When cohesion is taken into account, the safety factor in shall be at least:

- 3 for design loads (2.5 if cohesion values are verified by tests)
- 2 for unusual and extreme loads (1.5 if cohesion values are verified by tests).

If friction angles are not documented through tests, the following maximum values may be used:

- 50° for hard rock, rough surface and favourable schistosity in the mineral/concrete transition;

- 45° for hard rock, low roughness with clear schistosity and loose rocks without schistosity;
- 40° for loose rocks with clear schistosity;
- 45° for sliding plane in the concrete body.

SWEDEN

REGULATIONS

In Sweden, there are no specific Regulations concerning the stability of concrete dams.

Dam safety guidelines are issued by the association of Swedish power companies (*Svensk Energi*). An updated version of the main document of the guidelines containing general dam safety requirements has been issued in 2002.

Safety guidelines for concrete dams have been issued in 2000. These are still regarded as preliminary and will be revised during 2003-2004.

NORMAL PRACTICE

The current preliminary guidelines for concrete dams are based on normal practice used in the design of new concrete dams in Sweden. There are no special considerations made to safety assessment of existing dams.

The guidelines are valid for both ordinary gravity dams and buttress dams.

Load combinations

Load combinations are considered as normal, exceptional or accidental.

Normal load cases are:

- dead weights, hydrostatic pressure and uplift at maximum reservoir level and ice pressure (50-200 kN per meter dam)
- loads during floods up to the 100 year flood.

Exceptional load cases are:

- dead weight, hydrostatic pressure and uplift for water level at dam crest
- loads during design flood (PMF for high hazard dams),
- loads during the construction period
- loads from asymmetric ice pressures
- increased uplift due to clogged drains

Examples of accidental load cases are malfunction of discharge facilities.

Safety against sliding

The safety against sliding has to be assessed for the interface between the dam and the foundation, as well as for surfaces within the dam body and in the underlying foundation.

108 SLIDING SAFETY OF EXISTING GRAVITY DAMS

No safety criteria for sliding surfaces within the dam body or the foundation are given in the guidelines. Sliding in lift joints within the dam body may be assessed according to rules in the concrete code. Sliding within the dam foundation has to be considered by a case-by-case approach.

The safety against sliding in the dam-foundation interface is assessed by using a conventional rigid body equilibrium method. A sliding factor (friction coefficient) is calculated expressed as the resultant of all forces parallel to the sliding surface divided by the resultant of all forces perpendicular to the sliding surface.

For dams founded on good quality rock it is stipulated that the sliding factor has to be at least:

- 0.75 for normal load cases,
- 0.90 for exceptional load cases
- 0.95 for accidental load cases.

INDIA

REGULATIONS

Indian Standards Institution has edited : Criteria for design of solid gravity dams IS : 6512 - 1984 (first revision march 1985)

REGULATORY RULES

Load combinations

Seven load combinations are considered:

- A) Dam completed, but with no water
- B) Full reservoir elevation, normal uplift, ice and silt (if applicable)
- C) Reservoir and tailwater at maximum flood elevation, normal uplift, silt
- D) Earthquake with dam completed, but empty
- E) Earthquake, full reservoir, normal uplift, silt
- F) Reservoir and tailwater at maximum flood elevation, with extreme uplift (drains inoperative), silt
- G) Earthquake, full reservoir, extreme uplift (drains inoperative), silt.

Material properties

The value of cohesion and internal friction may be estimated for the purpose of preliminary design on the basis of available data on similar or comparable materials. For final designs, the value of cohesion and friction shall be determined by actual laboratory and field tests (see IS 7746-1975 Code of practice for in-situ shear test on rocks).

Sliding stability

The factor of safety against sliding shall be computed from the following equation and shall not be less than 1.0 :

$$F = \left[\frac{\tan(\phi) \cdot (W - U)}{F_\phi} + \frac{c \cdot A}{F_c} \right] * \frac{1}{P}$$

- F = factor of safety against sliding,
- W = total mass of the dam
- U = total uplift force,
- $\tan \phi$ = coefficient of internal friction of the material,
- c = cohesion of the material at the plane considered,
- A = area under consideration for cohesion,
- F_ϕ = partial factor of safety in respect of friction,
- F_c = partial factor of safety in respect of cohesion,
- P = total horizontal force

Values of the partial safety factors:

Loading Combination	F_ϕ	F_c		
		For dam body and the contact with foundation	For foundation	
			Thoroughly investigated	Others
A, B, C	1.5	3.6	4.0	4.5
D, E	1.2	2.4	2.7	3.0
F, G	1	1.2	1.35	1.5

AUSTRIA**REGULATION**

In Austria special technical requirements and procedures apply to dams higher than 15 m above foundation level or impounding reservoirs with a capacity of more than 500.000 m³. For evaluating dam safety only a relatively small number of technical guidelines are laid down so far. The competence lies with people having an excellent professional knowledge and profound experience. This concept is laid down by R. Melbinger in

110 SLIDING SAFETY OF EXISTING GRAVITY DAMS

“The Austrian Approach to Dam Safety: A Symbiosis of Rules and Engineering Judgement”, Proc. Of Int. Symposium on Dam Safety, Barcelona, 1998.

No regulations exist for the assessment of sliding safety of existing concrete dams. For the examination of safety analyses for fill dams recommendations are available.

Recently (between 1996 to 2001), recommendations for the safety assessment of concrete and fill dams for the earthquake analysis have been released by the Austrian Commission on Dams, which contain some statements to this topic, but no specifications.

COMMON PRACTICE

For gravity dams, assessment of the sliding stability is carried out for the base joint as well as for construction joints in the dam body. Uplift pressure has to be taken into account and, in general, no effective tensile stresses are allowed. This analysis is carried out according to Lieckfeldt.

For the uplift pressure, the following assumptions are generally employed at least under normal loading condition:

- 85% of the head of water at the upstream surface, respectively at the crack tip,
- 100% in open joints,
- zero, or if applicable tail-water level at downstream,
- linear decreasing from upstream or crack tip to downstream.

Lower uplift pressure figures are allowed, e.g. downstream of a drainage curtain. In these cases, normally, the lower values have to be verified by measurements.

For the assessment of the safety against sliding, only the cross section remaining in contact has to be considered. The normal force is reduced by the uplift pressure acting in the open joint and the section in contact. The shear strength has to be based either on test results for the dam under investigation or for similar situations.

As sliding safety factors ‘s’ the following values are normally applied:

- | | |
|---------------------------|----------|
| - Normal (Usual) Loading | s = 1,5 |
| - Unusual Loading; flood | s = 1,35 |
| - Earthquake Loading, OBE | s = 1,2 |
| - Extreme Loading; MCE | s = 1,1 |

Abb. 1: Uplift figure without drainage curtain

